

SocketModem™ GSM/GPRS

Embedded Data/Fax Wireless Modem

MTSMC-G-F1 – Global GSM/GPRS Class 10, 900/1800 MHz

MTSMC-G-F2 – Global GSM/GPRS Class 10, 850/1900 MHz

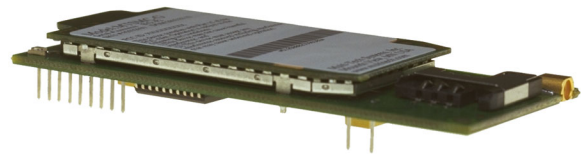

Developer's Guide

MultiTech®
Systems 

Table of Contents

CHAPTER 1 – PRODUCT DESCRIPTION AND SPECIFICATIONS	4
PRODUCT DESCRIPTION	4
APPLICATIONS.....	4
PRODUCT FEATURES.....	5
FEATURE DETAILS.....	5
DEVELOPER’S KIT	5
TECHNICAL SPECIFICATIONS.....	6
RELATED MANUALS.....	6
ADDITIONAL INFORMATION	6
CHAPTER 2 – MECHANICAL SPECIFICATIONS	7
PHYSICAL DIMENSIONS.....	7
PIN CONFIGURATIONS	8
<i>Pin Descriptions</i>	8
CHAPTER 3 – ELECTRICAL CHARACTERISTICS	9
I/O ELECTRICAL CHARACTERISTICS	9
POWER CONSUMPTION.....	9
SIM INTERFACE ELECTRICAL CHARACTERISTICS	10
HANDLING PRECAUTIONS	10
CHAPTER 4 – SOCKETMODEM INTERFACES	11
FLASHING LED	11
SIM INTERFACE	11
RF INTERFACE.....	12
<i>RF Connector</i>	12
<i>RF Performances</i>	12
CHAPTER 5 – SOCKETMODEM TEST BOARD	13
SERIAL TEST/DEMO BOARD COMPONENTS.....	13
SERIAL TEST/DEMO BOARD BLOCK DIAGRAM.....	13
CHAPTER 6 – APPLICATION CONSIDERATIONS	16
GENERAL GUIDELINES FOR THE USE OF THE SOCKETMODEM.....	16
<i>Hardware and RF</i>	16
<i>The Antenna</i>	16
FIRMWARE UPGRADE	16
INITIAL CONFIGURATION USING MOBILE PHONETOOLS.....	16
APPENDIX A – SAFETY PRECAUTIONS & REGULATORY STANDARDS COMPLIANCE	17
SAFETY PRECAUTIONS	17
<i>RF Safety</i>	17
<i>General Safety</i>	18
<i>Safety Standards</i>	19
<i>RF Exposures</i>	19
<i>Instructions to OEMs</i>	19
REGULATORY STANDARDS COMPLIANCE	20
<i>GSM compliance</i>	20
APPENDIX B – SOURCES FOR PERIPHERAL DEVICES	21
GSM ANTENNA.....	21
APPENDIX C – AT COMMAND LIST	22
APPENDIX D – ACRONYMS AND ABBREVIATIONS	26
INDEX	27

Chapter 1 – Product Description and Specifications

Product Description

The Multi-Tech SocketModem GSM/GPRS is a complete, ready-to-integrate, embedded wireless modem. Designed for global use, it offers standards-based multi-band GSM/GPRS Class 10. The SocketModem GSM/GPRS is based on industry-standard open interfaces and utilizes the same form factor as the SocketModem, SocketModem IP, or SocketEthernet IP modules from Multi-Tech.

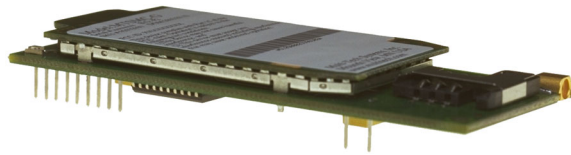

Multi-Tech's Wireless SocketModem GSM/GPRS

Product	Description	Region
MTSMC-G-F1	GMS/GPRS Class 10, 900/1800 MHz	Global
MTSMC-G-F2	GMS/GPRS Class 10, 850/1900 MHz	Global

Applications

The GSM/GPRS SocketModems are used to integrate wireless data and fax communications into numerous embedded applications. They are targeted at applications that periodically need to send or receive data over a wireless network and are ideal solutions for:

- Appliances
- ATM terminals
- Automotive
- Data collection
- Gas pumps
- Industrial and medical remote monitoring systems
- Remote diagnostics
- Remote metering
- Security systems
- Vending/gaming machines
- Other devices requiring wireless connectivity

Product Features

- GPRS Class 10
- Dual-band 850/1900 or 900/1800 GSM/GPRS
- GSM Class 1 and Class 2 Group 3 FAX
- Short Message Services features including text and PDU, point to point, cell broadcast
- 14.4K GSM circuit switched data
- MMCX antenna connector and SIM socket
- Serial interface supports DTE speeds to 115.2K
- AT command compatible*
- V.42bis data compression
- ME + SIM phone book management

***AT Commands** - AT commands for this product are published in a separate document available on the system CD and from Multi-Tech. For a copy of this documents contact OEM Sales at: oemsales@Multi-Tech.com or call (800) 972-2439.

Feature Details

Integration Reduces Space, Power, and Cost – The SocketModem GSM/GPRS integrates the controller, RF transceiver, and antenna interface in one module. This integration requires low power, low real estate and provides an overall reduction in costs.

Reduces Development Time – The SocketModem GSM/GPRS can make your existing and next generation device, machine, or system, communication-ready without requiring significant hardware changes to its design. This complete, ready-to-integrate wireless SocketModem allows you to enhance your product while you focus on developing its core features.

Short Message Services – The SocketModem GSM/GPRS offers SMS features such as text and PDU, point-to-point (MT/MO) and cell broadcast.

Management Features – The SocketModem GSM/GPRS provides advanced management features that include: phone book management, fixed dialing number, real time clock and alarm management.

Industry-standard Modem Commands – The SocketModem GSM/GPRS provides industry-standard AT-style commands for ease of integration into your existing software application.

SocketModem Pin-Out – The SocketModem GSM/GPRS interfaces easily with existing products through a standard serial communication channel. The complete on-board RF transceiver interfaces with an antenna for direct connection to wireless SMS, circuit-switched dial-up, or packet data networks. The SocketModem also includes an onboard LED to display network status. The SocketModem is a Data Terminal Equipment (DTE) device with serial asynchronous protocol support. The serial DTE channel is capable of transfer speeds to 115.2K bps and can be interfaced directly to a UART or microcontroller.

Developer's Kit

The SocketModem GSM/GPRS Developer's Kit allows you to plug in the SocketModem and use it for testing, programming, and evaluation. The kit includes:

- one development board
- RS-232 DB-25 connector
- universal power supply
- antenna
- RS-232 cable

Technical Specifications

The SocketModem GSM/GPRS meets the following specifications:

Fax Compatibility	GSM Class 1 and Class 2 Group 3 Fax
Weight	26 g (1 oz.)
Dimensions	3.1" w x 1.4" h x 0.5" d (8.0 cm x 3.5 cm x 1.2 cm)
Power Requirements	5 VDC; 400mA Average, 2A Peak
Operating Environment	-20° to +55° C
Storage Temperature	-30° to +85° C
Certifications	CE Mark EMC: FCC Part 2, 15, 22, 24, EN 55022 & EN55024 Safety: UL 60950, EN 60950
Cleaning	No cleaning/washing due to the manufacturing process used to produce this product

Additional Information

European Telecommunications Standards Institute (ETSI) - Contact the ETSI at:

650, route des Lucioles
06921 Sophia-Antipolis Cedex
France
Tel: +33 (0)4 92 94 42 00
Fax: +33 (0)4 93 65 47 16
<http://www.etsi.org>

Global Engineering Documents manages a collection of more than one million documents from over 460 organizations worldwide:

<http://global.ihs.com>
Phone: 800-854-7179
Fax: 303-792-2192

The ITU is the leading publisher of telecommunication technology, regulatory and standard information, with over 4,000 titles in printed form, on CD-ROM and online at:

[http://www.itu.int/publications/.](http://www.itu.int/publications/)

Chapter 2 – Mechanical Specifications

Physical Dimensions

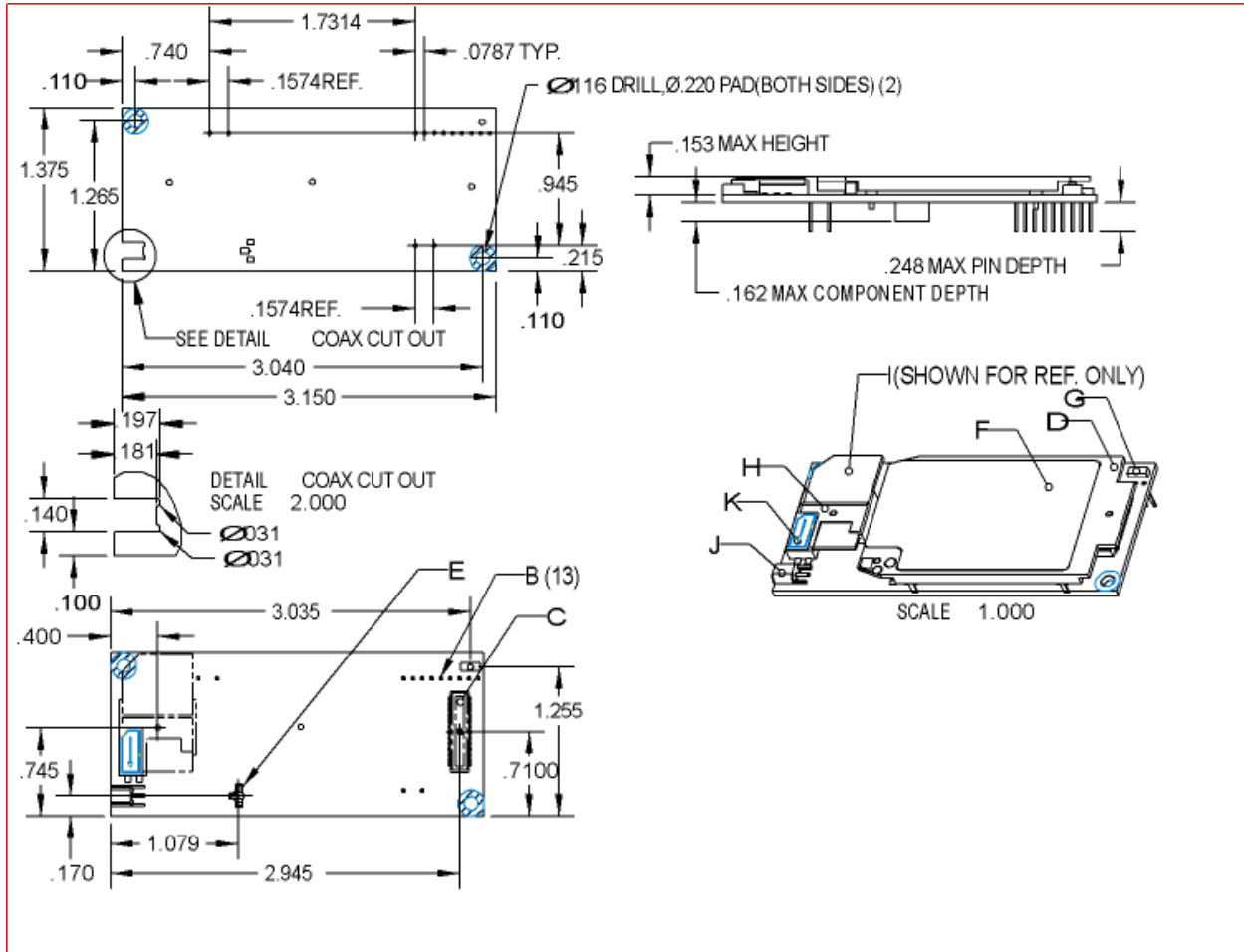

SocketModem GSM/GPRS Mechanical Drawing

Pin Configurations

The SocketModem GSM/GPRS uses a 13-pin interface.

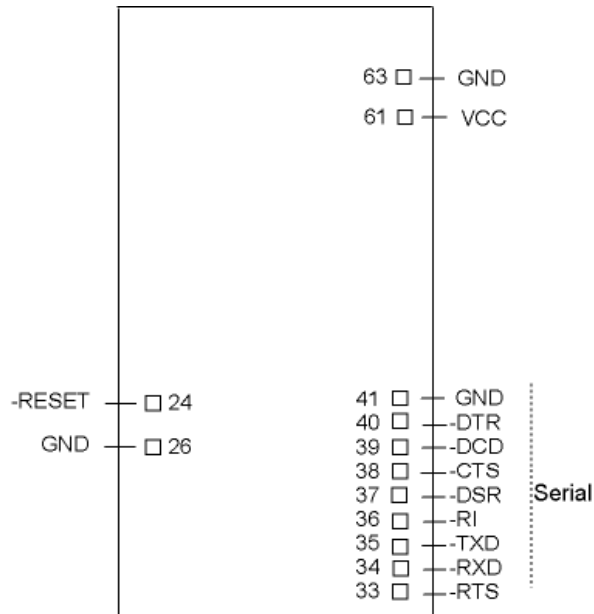

SocketModem Pins - Top View

Pin Descriptions

Pin #	Signal Name	I/O Type	Description
24	-RESET	I	Reset. This signal is used to force a reset procedure by providing low level during at least 500 μ s. This signal has to be considered as an emergency reset only. A reset procedure is already driven by an internal hardware during the power-up sequence. This signal can also be used to provide a reset to an external device. It then behaves as an output. If no external reset is necessary, this input can be left open. If used (emergency reset), it has to be driven by an open collector or an open drain.
26, 41, 63	GND		Ground
33	-RTS	I	Request to Send. RTS signal is used for hardware flow control.
34	-RXD	O	Received Data. The modem uses the RXD line to send received data to the DTE and to send modem responses to the DTE.
35	-TXD	I	Transmitted Data. The DTE uses the -TXD line to send data to the modem or to transmit commands to the modem.
36	-RI	O	Ring Indicate. -RI output ON (low) indicates the presence of an ON segment of a ring signal.
37	-DSR	O	Data Set Ready. -DSR indicates modem status to the DTE. -DSR OFF (high) indicates that the DTE is to disregard all signals appearing on the interchange circuits except Ring Indicator (-RI). It reflects the status of the local data set, and does not indicate an actual link with any remote data equipment.
38	-CTS	O	Clear To Send. -CTS is controlled by the modem to indicate whether or not the modem is ready to transmit data. -CTS ON, indicates to the DTE that signals presented on TXD will be transmitted. -CTS OFF indicates to the DTE that it should not transfer data across the interface on TXD.
39	-DCD	O	Data Carrier Detect. -DCD output is ON (low) when a data connection is established.
40	-DTR	I	Data Terminal Ready (Active Low). The -DTR input is turned ON (low) by the DTE when the DTE is ready to transmit or receive data. -DTR ON prepares the modem to be connected, and, once connected, maintains the connection. -DTR OFF places the modem in the disconnect state.
61	VCC	PWR	+5V

Chapter 3 – Electrical Characteristics

Electrical characteristics for the 5V Serial SocketModem are presented in this chapter.

I/O Electrical Characteristics

5 Vdc Characteristics (TA = -20° C to 55° C; VDD = 5 V ± 0.25 V) VDDMAX = 5.25 V

Digital Inputs –DTR (40), –TXD (35), –RTS (33), –RESET (24)	Input High Min 3.675 V	Input Low Max 1.4 V	
Digital Outputs –DCD (39), –CTS (38), –DSR (37), –RI (36), –RXD (34)	Output High Min. 4 V	Output Low Max 0.4 V	Current Drive: 2 ma 5 PF
Digital Input Capacitance			

Power Consumption

Power Consumption in OFF Mode

	Conditions	I _{NOM}	I _{MAX}
Overall Consumption	Off	5 µA	10 µA

Power Consumption in EGSM/GPRS 900 MHz and GSM/GPRS 850 MHz Mode

	Conditions	I _{NOM}	I _{MAX}
+5V	During TX bursts @Pcl5	1.7 A peak	2.0 A peak
+5V	During RX bursts	75 mA peak	80 mA peak
+5V	Average 1 Rx/1Tx @Pcl5	270 mA	370 mA
+5V	Average 1 Rx/1Tx @Pcl8	180 mA	200 mA
+5V	Average Idle Mode	100 µA	300 µA
+5V	Average 1 GPRS CI 10 (3Rx/2Tx) @Pcl5	540 mA	640 mA
+5V	Average 1 GPRS CI 10 (3Rx/2Tx) @Pcl8	360 mA	400 mA
+5V	Average 1 Idle Mode	2.2 mA	3 mA

Power Control Level: Pcl5=2W typ.; Pcl8=0,5W typ.

Power Consumption in GSM/GPRS 1800 & 1900 MHz Modes

	Conditions	I _{NOM}	I _{MAX}
+5V	During TX bursts @Pcl0	1.3 A peak	1.7 A peak
+5V	During RX bursts	75 mA peak	80 mA peak
+5V	Average 1 Rx/1Tx @Pcl0	240 mA	270 mA
+5V	Average 1 Rx/1Tx @Pcl3	150 mA	180 mA
+5V	Average Idle Mode	100 µA	300 µA
+5V	Average 1 GPRS CI 10 (3Rx/2Tx) @Pcl0	480 mA	540 mA
+5V	Average 1 GPRS CI 10 (3Rx/2Tx) @Pcl3	300 mA	360 mA
+5V	Average 1 Idle Mode	2.2 mA	3 mA

Power Control Level: Pcl0=1W typ.; Pcl3=0,25W typ.

SIM Interface Electrical Characteristics

SIM Interface Electrical Characteristics

This information is repeated in the next chapter under the SIM Interface section.

Parameter	Conditions	Min	Typ	Max	Unit
SIMDATA V_{IH}	$I_{IH} = +/- 20\mu A$	$0.7 \times SIMVCC$			V
SIMDATA V_{IL}	$I_{IL} = 1 \text{ mA}$			$0.3 \times SIMVCC$	V
SIMRST, SIMDATA SIMCLK V_{OH}	Source current $= 20\mu A$	$SIMVCC - 0.1V$			V
SIMRST, SIMDATA SIMCLK V_{OL}	Sink current $= -200\mu A$			0.1	
SIMVCC Output Voltage	$I_{SIMVCC} \leq 6 \text{ mA}$	2.70	2.80	2.85	V
SIMCLK Rise/Fall Time	Loaded with 30pF			50	ns
SIMRST, SIMDATA Rise/Fall Time	Loaded with 30pF			1	μs
SIMCLK Frequency	Loaded with 30pF			3.25	MHz

Handling Precautions

All devices must be handled with certain precautions to avoid damage due to the accumulation of static charge. Although input protection circuitry has been incorporated into the devices to minimize the effect of this static buildup, proper precautions should be taken to avoid exposure to electrostatic discharge during handling and mounting.

Chapter 4 – SocketModem Interfaces

This chapter describes the SocketModem interfaces.

- Flashing LED
- SIM Interface
- RF Interface

Flashing LED

The flashing LED signal is used to indicate the working mode of the SocketModem.

LED and SocketModem Status

Signal	SocketModem Status	
OFF	Download mode or switched OFF>	
ON	Continuously lit	Switched ON (not registered on the network)
	Flashing	Switched ON (registered on the network)

SIM Interface

The internal SIM interface of the SocketModule supports 3V SIMs only.

Note: This interface is fully compliant with GSM 11.11 recommendations concerning the SIM functionality.

Five Signals Are Available

SIMVCC: SIM power supply.

SIMRST: reset.

SIMCLK: clock.

SIMDATA: I/O port.

SIMPRES1 SIM card detect.

RF Interface

The impedance is 50 Ohms nominal.

RF Connector

The RF connector is MMCX standard type. An antenna can be directly connected through the mating connector or using a small adapter.

RF Performances

RF performances are compliant with the ETSI recommendation 05.05 and 11.10.

The main parameters are:

Receiver:

- EGSM Sensitivity : < -104 dBm
- GSM 1800/GSM 1900 Sensitivity : < -102 dBm
- Selectivity @ 200 kHz : > +9 dBc
- Selectivity @ 400 kHz : > +41 dBc
- Dynamic range : 62 dB
- Intermodulation : > -43 dBm
- Co-channel rejection : + 9 dBc

Transmitter:

- Maximum output power (EGSM) : 33 dBm +/- 2 dB
- Maximum output power (DCS/PCS) : 30 dBm +/- 2 dB
- Minimum output power (EGSM): 5 dBm +/- 5 dB
- Minimum output power (DCS/PCS): 0 dBm +/- 5 dB
- H2 level : < -30 dBm
- H3 level : < -30 dBm
- Noise in 925 - 935 MHz : < -67 dBm
- Noise in 935 - 960 MHz : < -79 dBm
- Noise in 1805 - 1880 MHz : < -71 dBm
- Phase error at peak power : < 5 ° RMS
- Frequency error : +/- 0.1 ppm max

Chapter 5 – SocketModem Test Board

Serial Test/Demo Board Components

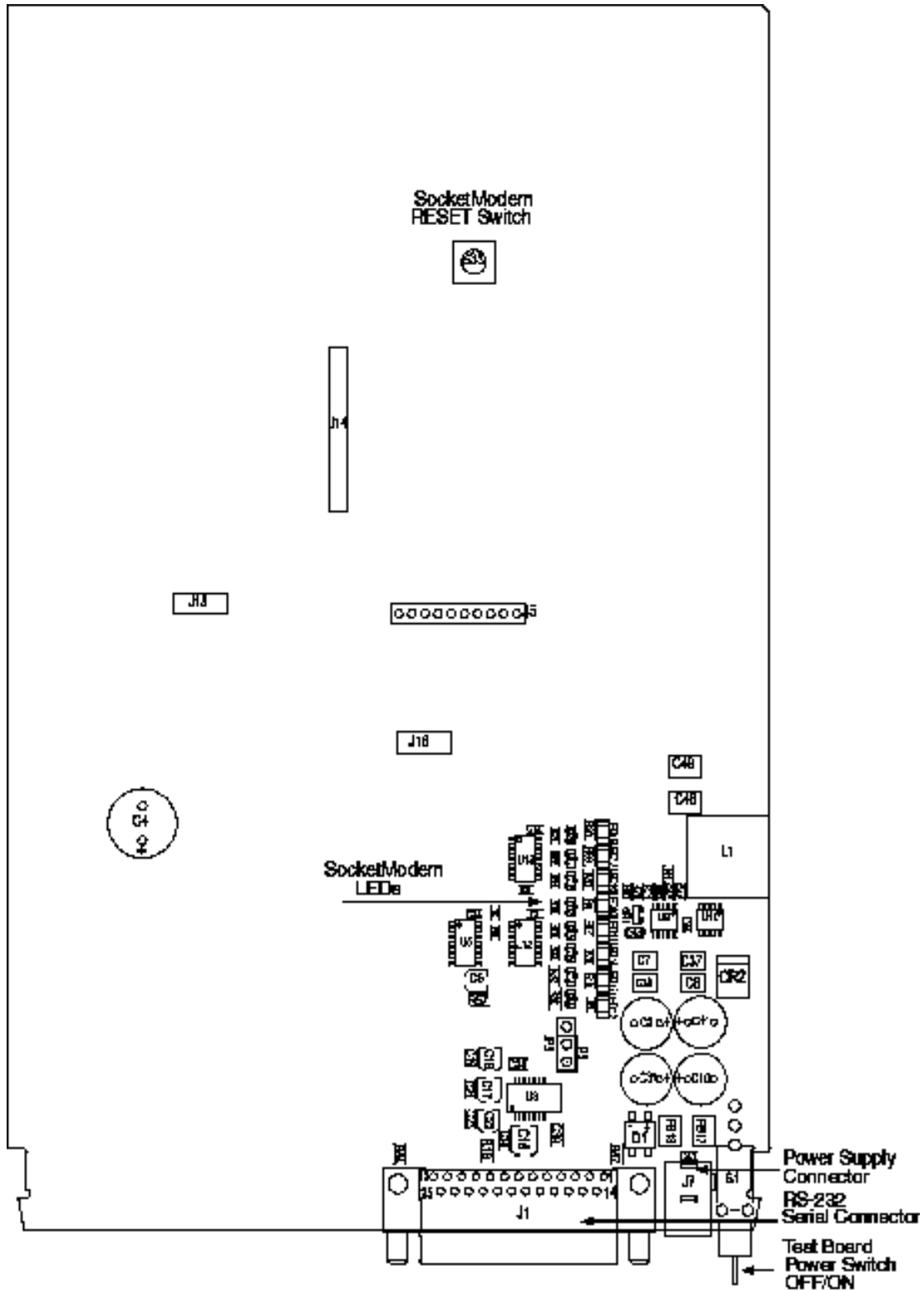

Serial Test/Demo Board Block Diagram

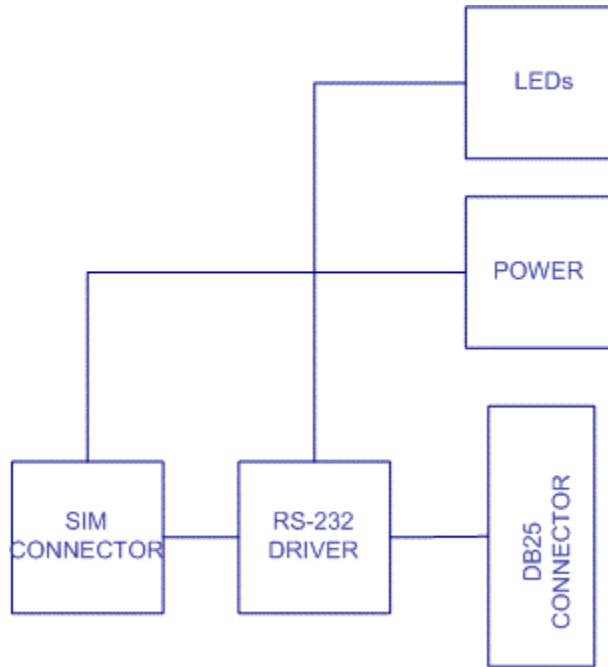

Block Diagram for the SocketModem GSM/GPRS

Chapter 6 – Application Considerations

General Guidelines for the Use of the SocketModem

Hardware and RF

- Ground plane: Multi-Tech recommends having a common ground plane for analog, digital and RF grounds.
- ESD protection on serial link, ...
- Possible spurious emission radiated by the application to the RF receiver in the receiver band

The Antenna

The antenna sub-system and integration in the application is a major issue. It is a major issue in the choice of the antenna cable (type, length, performances, thermal resistance, etc.)

These elements could affect GSM performances such as sensitivity and emitted power.

The antenna should be isolated as much as possible from the digital circuitry including the interface signals.

Multi-Tech recommends shielding the terminal. On terminals including the antenna, a poor shielding could dramatically affect the sensitivity of the terminal. Subsequently, the power emitted through the antenna could affect the application.

Firmware Upgrade

The SocketModem firmware is stored in flash memory and it can easily be upgraded. The upgrade procedure is based on the Xmodem protocol (AT+WDWL command).

Nominal Upgrade Procedure

The firmware file can be downloaded into the modem using the Xmodem protocol. To enter this mode, the AT+WDWL command (see description in the AT command manual) has to be sent to the SocketModem.

The necessary serial signals to proceed with the Xmodem downloading are: Rx, Tx, RTS, CTS, GND.

Initial Configuration Using Mobile PhoneTools

For initial configuration of your wireless device, Multi-Tech offers a Windows-based mobile PhoneTools application.

To load Mobile PhoneTools, click the Mobile PhoneTools icon on the system CD and follow the on-screen prompts.

Appendix A – Safety Precautions & Regulatory Standards Compliance

Safety Precautions

IMPORTANT!

FOR THE EFFICIENT AND SAFE OPERATION OF YOUR GSM INTEGRATED MODEM READ THIS INFORMATION BEFORE USE.

RF Safety

General

Your SocketModem is based on the GSM standard for cellular technology. The GSM standard is spread all over the world. It covers Europe, Asia, and some parts of America and Africa. This is the most used telecommunication standard. Your modem is actually a low power radio transmitter and receiver. It sends out and receives radio frequency energy. When you use your SocketModem integrated modem, the cellular system, which handles your calls controls both the radio frequency and the power level of your cellular modem.

Exposure to RF Energy

There has been some public concern about possible health effects of using GSM modems. Although research on health effects from RF energy has focused on the current RF technology for many years, scientists have begun research regarding newer radio technologies, such as GSM. After existing research had been reviewed, and after compliance to all applicable safety standards had been tested, it has been concluded that the product was fitted for use. If you are concerned about exposure to RF energy there are things you can do to minimize exposure. Obviously, limiting the duration of your calls will reduce your exposure to RF energy. In addition, you can reduce RF exposure by operating your cellular modem efficiently by following the below guidelines.

Efficient Modem Operation

For your modem to operate at the lowest power level, consistent with satisfactory call quality :

- If your modem has an extendible antenna, extend it fully. Some models allow you to place a call with the antenna retracted. However your modem operates more efficiently with the antenna fully extended.
- Do not hold the antenna when the modem is « IN USE ». Holding the antenna affects call quality and may cause the modem to operate at a higher power level than needed.

Antenna Care and Replacement

Do not use the modem with a damaged antenna. If a damaged antenna comes into contact with the skin, a minor burn may result. Replace a damaged antenna immediately. Consult your manual to see if you may change the antenna yourself. If so, use only a manufacturer-approved antenna. Otherwise, have your antenna repaired by a qualified technician. Use only the supplied or approved antenna.

Unauthorized antennas, modifications, or attachments could damage the modem and may contravene local RF emission regulations or invalidate type approval.

General Safety

Driving

Check the laws and the regulations regarding the use of cellular devices in the area where you have to drive as you always have to comply with them. When using your modem while driving, please : give full attention to driving, pull off the road and park before making or answering a call if driving conditions so require.

Electronic Devices

Most electronic equipment, for example in hospitals and motor vehicles is shielded from RF energy. However RF energy may affect some improperly shielded electronic equipment.

Vehicle Electronic Equipment

Check your vehicle manufacturer representative to determine if any on-board electronic equipment is adequately shielded from RF energy.

Medical Electronic Equipment

Consult the manufacturer of any personal medical devices (such as pacemakers, hearing aids, etc...) to determine if they are adequately shielded from external RF energy. Turn your modem OFF in health care facilities when any regulations posted in the area instruct you to do so. Hospitals or health care facilities may be using RF monitoring equipment.

Aircraft

Turn your modem OFF before boarding any aircraft.

- Use it on the ground only with crew permission.
- Do not use it in the air.

To prevent possible interference with aircraft systems, Federal Aviation Administration (FAA) regulations require you to have permission from a crew member to use your modem while the aircraft is on the ground. To prevent interference with cellular systems, local RF regulations prohibit using your modem while airborne.

Children

Do not allow children to play with your modem. It is not a toy. Children could hurt themselves or others (by poking themselves or others in the eye with the antenna, for example). Children could damage the modem, or make calls that increase your modem bills.

Blasting Areas

To avoid interfering with blasting operations, turn your unit OFF when in a « blasting area » or in areas posted : « turn off two-way radio ». Construction crew often use remote control RF devices to set off explosives.

Potentially Explosive Atmospheres

Turn your modem OFF when in any area with a potentially explosive atmosphere. It is rare, but your modem or its accessories could generate sparks. Sparks in such areas could cause an explosion or fire resulting in bodily injuries or even death. Areas with a potentially explosive atmosphere are often, but not always, clearly marked. They include fueling areas such as petrol stations; below decks on boats; fuel or chemical transfer or storage facilities; and areas where the air contains chemicals or particles, such as grain, dust, or metal powders. Do not transport or store flammable gas, liquid, or explosives, in the compartment of your vehicle, which contains your modem or accessories. Before using your modem in a vehicle powered by liquefied petroleum gas (such as propane or butane) ensure that the vehicle complies with the relevant fire and safety regulations of the country in which the vehicle is to be used.

Safety Standards

THIS WIRELESS SOCKETMODEM COMPLIES WITH ALL APPLICABLE RF SAFETY STANDARDS. This cellular modem meets the standards and recommendations for the protection of public exposure to RF electromagnetic energy established by governmental bodies and other qualified organizations, such as the following :

- Directives of the European Community,
- Directorate General V in Matters of Radio Frequency Electromagnetic Energy

RF Exposures

Pursuant to 47 CFR § 24.52 of the FCC Rules and Regulations, personal communications services (PCS) equipment is subject to the radio frequency radiation exposure requirements specified in § 1.1307(b), § 2.1091 and § 2.1093 as appropriate.

The Multi-Tech SocketModem is a GSM (PCS 1900) terminal which operates in the US licensed PCS frequency spectrum. The device transmits over the 1850-1910 MHz band and receives over the 1930-1990 MHz Band. Multi-Tech Systems, Inc. certifies that it has determined that the Modem complies with the RF hazard requirements applicable to broadband PCS equipment operating under the authority of 47 CFR Part 24, Subpart E of the FCC Rules and Regulations. This determination is dependent upon installation, operation and use of the equipment in accordance with all instructions provided.

The modem is designed for and intended to be used in fixed and mobile applications. "Fixed" means that the device is physically secured at one location and is not able to be easily moved to another location. "Mobile" means that the device is designed to be used in other than fixed locations and generally in such a way that a separation distance of at least 20 cm is normally maintained between the transmitter's antenna and the body of the user or nearby persons. The Modem is not designed for or intended to be used in portable applications (within 20 cm of the body of the user) and such uses are strictly prohibited. To ensure that the unit complies with current FCC regulations limiting both maximum RF output power and human exposure to radio frequency radiation, a separation distance of at least 20 cm must be maintained between the unit's antenna and the body of the user and any nearby persons at all times and in all applications and uses. Additionally, in mobile applications, maximum antenna gain must not exceed 3 dBi (to comply with Section 24.232(b) and is limited to 7 dBi for fixed applications. Finally, the tune-up procedure for the O9EM2113 ensures that the maximum RF output power of the device does not exceed 30.0 dBm within the variations that can be expected due to quantity production and testing on a statistical basis.

Instructions to OEMs

The Multi-Tech product manual includes specific warnings and cautions in order to ensure that OEMs are aware of their responsibilities, with regards to RF exposure compliance, for products into which the modem is integrated. With this guidance, the OEM will be able to incorporate into their documentation the necessary operating conditions and warnings.

OEMs need to provide a manual with the "final" product that clearly states the operating requirements and conditions and that these must be observed to ensure compliance with current FCC RF exposure requirements / MPE limits (see the "RF Exposures" section above). This will enable the OEM to generate (and provide the end-user with) the appropriate operating instructions, warnings and cautions, and/or markings for their product.

Regulatory Standards Compliance

GSM compliance

The SocketModem is in compliance with reference regulations: TBR 19, TBR 20, TBR 31, TBR 32.

CE Label

The Wireless SocketModem is CE compliant, which implies that the modem is in conformity with the European Community directives and it bears the CE label.

Appendix B – Sources for Peripheral Devices

GSM Antenna

The integrated modem antenna connector is a MMCX connector. The MMCX connector incorporates a 'Snap On' latching action in order to make the connection easier with an excellent RF performance. An additional advantage is its small physical size, which is 50% of the standard MCX connector.

This type of connector is suitable for the standard ranges of flexible and semi-rigid cables. The characteristic impedance of the MMCX coaxial connector is 50 ohm. The antenna manufacturer must guarantee that the antenna will be working according to the radio characteristics presented in the table below.

Radio Characteristics

	GSM 850	EGSM 900	GSM 1800	GSM 1900
Frequency RX	869 to 894 MHz	925 to 960 MHz	1805 to 1880 MHz	1930 to 990 MHz
Frequency TX	824 to 849 MHz	880 to 915 MHz	1710 to 1875 MHz	1850 to 910 MHz
RF Power Stand	2W at 12.5% duty cycle	2W at 12.5% duty cycle	1W at 12.5% duty cycle	1W at 12.5% duty cycle
Impedance	50 ohms			
VSWR	<2			
Typical Radiated Gain	0 dBi on azimuth plane			

MMCX Plug

The SocketModem requires an MMCX plug to connect to an antenna.



MMCX Connector Example (right angle type)

Antenna

An antenna with matting connector can be ordered, for example, from:

IMS Connectors Systems GMBH

<http://www.imscs.com/>

MMCX / SMA Adapter

A small MMCX / SMA adapter can be ordered, for example, from:

Amphenol

<http://www.amphenol.com/>

Order No: 908-31100

Appendix C – AT Command List

For comprehensive information about AT Commands, please read the AT Commands Reference Manual.

AT Command List

General Commands	
+CGMI	Manufacturer Identification
+CGMM	Request Model Identification
+CGMR	Request Revision Identification
+CGSN	Product Serial Number
+CSCS	Select TE Character Set
+CIMI	Request IMSI
+CCID	Card Identification
+GCAP	Capabilities List
A/	Repeat Last Command
+CPOF	Power Off
+CFUN	Set Phone Functionality
+CPAS	Phone Activity Status
+CMEE	Report Mobile Equipment Errors
+CKPD	Keypad Control
+CCLK	Clock management
+CALA	Alarm management
Call Control Commands	
D	Dial command
H	Hang-up Command
A	Answer a Call
+CEER	Extended Error Report
+VTD, +VTS	DTMF Signals
ATDL	Redial Last Telephone Number
AT%Dn	Automatic Dialing (or SMS send) with DTR
ATSO	Automatic Answer
+CICB	Incoming Call Bearer
+VGR, +VGT	Gain Control
+CMUT	Microphone Mute Control
+SPEAKER	Speaker and Microphone Selection
+ECHO	Echo Cancellation
+SIDET	Side Tone Modification
+VIP	Initialize Voice Parameters
+CSNS	Single Numbering Scheme
Network Service Commands	
+CSQ	Signal Quality
+COPS	Operator Selection
+CREG	Network Registration
+WOPN	Read Operator Name
+CPOL	Preferred Operator List

AT Command List (cont'd)

Security Commands	
+CPIN	Enter PIN
+CPIN2	Enter PIN2
+CPINC	PIN Remaining Attempt Number
+CLCK	Facility Lock
+CPWD	Change Password
Phone Book Commands	
+CPBS	Select Phone Book Memory Storage
+CPBR	Read Phone Book Entries
+CPBF	Find Phone Book Entries
+CPBW	Write Phone Book Entry
+CPBP	Phone Book Phone Search
+CPBN	Move Action in Phone Book
+CNUM	Subscriber Number
+WAIP	Avoid Phone Book Init
Short Message Commands	
+CSMS	Select Message Service
+CNMA	New Message Acknowledgement
+CPMS	Preferred Message Storage
+CMGF	Preferred Message Format
+CSAS	Save Settings
+CRES	Restore Settings
+CSDH	Show Text Mode parameters
+CNMI	New Message Indication
+CMGR	Read Message
+CMGL	List Message
+CMGS	Send Message
+CMGW	Write Message to Memory
+CMSS	Send Message from Storage
+CSMP	Set Text Mode Parameters
+CMGD	Delete Message
+CSCA	Service Center Address
+CSCB	Select Cell Broadcast Message Types
+WCBM	Cell Broadcast Message Identifiers
+WMSC	Message Status Modification
+WMGO	Message Overwriting

AT Command List (cont'd)

Supplementary Services Commands	
+CCFC	Call Forwarding
+CLCK	Call Barring
+CPWD	Modify SS Password
+CCWA	Call Waiting
+CLIR	Calling Line Identification Restriction
+CLIP	Calling Line Identification Presentation
+COLP	Connected Line Identification Presentation
+CAOC	Advice Of Charge
+CACM	Accumulated Call Meter
+CAMM	Accumulated Call Meter Maximum
+CPUC	Price Per Unit and Currency Table
+CHLD	Call Related Supplementary Services
+CLCC	List Current Calls
+CSSN	Supplementary Service Notifications
+CUSD	Unstructured Supplementary Service Data
+CCUG	Closed User Group
Data Commands	
+CBST	Bearer Type Selection
+FCLASS	Select Mode
+CR	Service Reporting Control
+CRC	Cellular Result Codes
+ILRR	DTE-DCE Local Rate Reporting
+CRLP	Radio Link Protocol Parameters
+DOPT	Others Radio Link Parameters
%C	Select Data Compression
+DS	V42 bis Data Compression
+DR	V42 bis Data Compression Report
\N	Select Data Error Correcting Mode
Fax Commands	
+FTM	Transmit Speed
+FRM	Receive Speed
+FTH	HDLC Transmit Speed
+FRH	HDLC Receive Speed
+FTS	Stop Transmission and Wait
+FRS	Receive Silence
Fax Class 2 Commands	
+FDT	Transmit Data
+FDR	Receive Data
+FET	Transmit Page Punctuation
+FPTS	Page Transfer Status Parameters
+FK	Terminate Session
+FBOR	Page Transfer Bit Order
+FBUF	Buffer Size Report
+FCQ	Copy Quality Checking
+FCR	Capability to Receive
+FDIS	Current Sessions Parameters
+FDCC	DCE Capabilities Parameters
+FLID	Local ID String
+FPHCTO	Page Transfer Timeout Parameter

AT Command List (cont'd)

V24 - V25 Commands	
+IPR	Fixed DTE Rate
+ICF	DTE-DCE Character Framing
+IFC	DTE-DCE Local Flow Control
&C	Set DCD Signal
&D	Set DTR Signal
&S	Set DSR Signal
O	Back to Online Mode
Q	Result Code Suppression
V	DCE Response Format
Z	Default Configuration
&W	Save Configuration
&T	Auto-Tests
E	Echo
&F	Restore Factory Settings
&V	Display Configuration
I	Request Identification Information
SIM Toolkit Commands	
+STSF	SIM Toolkit Set Facilities
+STIN	SIM Toolkit Indication
+STGI	SIM Toolkit Get Information
+STCR	SIM Toolkit Control Response
+STGR	SIM Toolkit Give Response
Specific AT Commands	
+CCED	Cell Environment Description
+CCED	Automatic RxLev Indication
+WIND	General Indications
+ADC	Analog Digital Converters Measurements
+CMER	Mobile Equipment Event Reporting
+WLPR	Read Language Preference
+WLPW	Write Language Preference
+WIOR	Read GPIO Value
+WIOW	Write GPIO Value
+WAC	Abort Command
+WTONE	Play Tone
+WDTMF	Play DTMF Tone
+WDWL	Multi-Tech Downloading
+WVR	Multi-Tech Voice Rate
+WDR	Data Rate
+WHWV	Hardware Version
+WDOP	Date Of Production
+WSVG	Multi-Tech Select Voice Gain
+WSTR	Multi-Tech Status Request
+WSCAN	Multi-Tech Scan
+WRIM	Ring Indicator Mode
+W32K	Power saving mode

Appendix D – Acronyms and Abbreviations

ADC – Analog Digital Converter
ASIC – Application Specific Integrated Circuit
BCCH – Broadcast Control Channel
CE – Communauté Européenne
CLK – Clock
CTS – Clear To send
dB – decibel
DCD – Data Carrier Detect
DCE – Data Circuit Terminating Equipment
DSR – Data Set Ready
DTE – Data Terminal Equipment
DTR – Data Terminated Ready
EFR – Enhanced Full Rate
EGSM – Extended GSM
EMC – Electromagnetic Conformity
EN – Enable
ETSI – European Telecommunications Standards Institute
FAC – Final Assembly Code
FR – Full-Rate
FTA – Full Type Approval
GND – Ground
GPIO – General Purpose Input Output
GPRS – General Packet Radio Service
GSM – Global System for Mobile Communication
HR – Half-Rate
IMEI – International Mobile Equipment Identity
MO – Mobile Originated
MT – Mobile Terminated
OEM – Original Equipment Manufacturer
PDA – Personal Digital Assistant
PCB – Printed Circuit Board
PRES – Presence
RI – Ring Indicator
RTS – Request To Send
SIM – Subscriber Identity Module
SMD – Surface Mounted Design
SMS – Short Message Service
TAC – Type Approval Code
TDMA – Time Code Multiple Access
TE – Terminal Equipment
VSWR – Voltage Standing Wave Ratio
WAP – Wireless Application Protocol

Index

- Advice Of Charge, 23
- aircraft and safety, 17
- analog, 25
- antenna, 12, 15, 16, 20
- antenna cable, 15
- [applications](#), 4
- AT command, 6
- [AT commands documentation](#), 5
- blasting areas and safety, 17
- Call Barring, 23
- Call Forwarding, 23
- Call Waiting, 23
- CE, 19, 25
- Cell Broadcast, 22
- children and safety, 17
- Closed User Group, 23
- connector, 12, 20
- Data Carrier Detect, 25
- dB, 12, 25
- DCS, 12
- driving safety, 17
- EFR, 25
- electronic devices and safety, 17
- ESD protection, 15
- ETSI, 12, 25
- explosive atmospheres and safety, 17
- firmware upgrad, 15
- FR, 25
- gain, 18
- GND, 25
- GPIO, 24, 25
- GPRS, 25
- GSM, 11, 12, 20, 25
- GSM Compliance, 19
- HR, 25
- I/O, 11
- Instructions to OEMs, 18
- interface, 11
- medical electronic equipment and safety, 17
- MMCX (Miniature Micro Connector), 12, 20
- MO, 25
- modem, 6, 20
- MT, 25
- operating conditions, 18
- PCB, 25
- PCS, 12, 18
- power, 11, 12, 15, 16
- power supply, 11
- radio, 16, 20
- RF, 12, 15, 16, 20
- RF Exposures, 18
- safety, 16
- Safety Standards, 18
- signal, 11
- SIM, 10, 11, 24, 25
- SIM Toolkit, 24
- SIMCLK, 10, 11
- SIMDATA, 10, 11
- SIMRST, 10, 11
- SIMVCC, 10, 11
- SMS, 21, 25
- [Specifications](#)
 - [technical](#), 6
- [Technical specifications](#), 6
- vehicle electronic equipment and safety, 17
- WAP, 25