

Fastrack Modem M13 Series

Fastrack Modem M1306B User Guide

Reference: **WM_PRJ_M13_UGD_001**
Revision: **001**
Date: **20th July 2004**



Document Information

Revision	Date	History of the evolution	
001	15 Jul 04	First Issue with Preliminary status	

Preliminary

Overview

The Fastrack M1306B is a discrete, rugged cellular modem offering state-of-the-art GSM/GPRS connectivity to machine to machine applications.

Proven for reliable, stable performance on wireless networks worldwide, WAVECOM's latest generation of Fastracks -M1306B- continues to deliver rapid time to market and painless integration.

Smaller than the former generation and updated with new features, the M1306B now offers 2 general purpose input/output access points and a serial autosutdown feature enabling energy conservation.

Fully certified, the dual band 900/1800 MHz Fastrack M1306B offers GPRS cl.10 capability and supports a powerful open software platform (Open AT) enabling cost-efficient designs to be achieved and capable of hosting any industrial or IT protocol.

Fastrack M1306B is controlled by firmware through a set of AT commands.

This document describes the modem and gives information about the following topics:

- General presentation,
- Functional description,
- Basic services available,
- Technical characteristics,
- Installing and using the modem,
- User-level troubleshooting,
- Recommended accessories to be used with the modem.

Contents

Document Information	2
Overview	3
Contents	4
Table of figures	7
Caution	8
Trademarks	8
Copyright	8
1 References	9
1.1 Reference Documents.....	9
1.2 Abbreviations	9
2 Packaging	12
2.1 Contents.....	12
2.2 Packaging box.....	13
2.3 Production sticker.....	14
3 General Presentation	15
3.1 Description	15
3.2 External connections	16
3.2.1 Connectors	16
3.2.1.1 Antenna connector.....	16
3.2.1.2 Power supply connector	17
3.2.1.3 Sub HD 15-pin connector.....	17
3.2.2 Power supply cable.....	19
4 Basic features and services	20

5	Using the modem	22
5.1	Getting started with the modem	22
5.1.1	Mounting the modem	22
5.1.2	Setting up the modem	22
5.1.3	Checking the communication with the modem	23
5.1.4	Resetting the modem	23
5.2	Specific recommendations when using the modem on trucks	24
5.2.1	Technical constraints on trucks	24
5.2.2	Recommended Power Supply connection on trucks	25
5.3	Operational status of the modem	26
5.4	Echo function disabled	26
5.5	Verifying the received signal strength	27
5.6	Checking the pin code status	28
5.7	Verifying the network registration of the modem	28
5.8	Main AT commands for the modem	29
5.9	Firmware upgrade procedure	30
6	Troubleshooting	31
6.1	No communication with the modem through the serial link	31
6.2	Receiving "ERROR" message	32
6.3	Receiving "NO CARRIER" message	32
7	Functional description	35
7.1	Architecture	35
7.2	Power supply	36
7.2.1	General presentation	36
7.2.2	Protections	36
7.3	RS232 serial link	37
7.3.1	General presentation	37
7.3.2	Green idle power saving mode	38
7.3.3	Autoshutdown facility	38
7.3.4	Autobauding mode	38
7.3.5	Pin description	38
7.4	General Purpose Input/Output (GPIO)	39
7.5	BOOT	39
7.6	RESET	40
7.6.1	General presentation	40
7.6.2	Reset sequence	41
7.7	Audio	42
7.7.1	Microphone inputs	42
7.7.2	Speaker outputs	42

8	Technical characteristics	43
8.1	Mechanical characteristics	43
8.2	Electrical characteristics	45
8.2.1	Power supply	45
8.2.2	Audio interface	47
8.2.3	General Purpose Input/output	48
8.2.4	SIM interface	48
8.2.5	RESET Signal	48
8.2.6	RF characteristics	49
8.2.6.1	Frequency ranges	49
8.2.6.2	RF performances	49
8.2.6.3	External antenna	50
8.3	Environmental characteristics	51
8.4	Conformity	52
8.5	Protections	52
8.5.1	Power supply	52
8.5.2	Overvoltage	52
8.5.3	ESD 52	
8.5.4	Miscellaneous	52
9	Safety recommendations	53
9.1	General Safety	53
9.2	Vehicle Safety	54
9.3	Care And Maintenance	54
9.4	Your Responsibility	54
10	Recommended accessories	55

Table of figures

Figure 1: Complete package contents	12
Figure 2: Packaging box	13
Figure 3: Production sticker	14
Figure 4: FASTRACK modem M1306B general description	15
Figure 5: FASTRACK modem M1306B holding bridles.....	16
Figure 6: SMA connector for antenna connection	16
Figure 7: Power supply connector	17
Figure 8: Sub HD 15-pin connector	18
Figure 9: Power supply cable.....	19
Figure 10: Modem mounting	22
Figure 11: Example of electrical connection which may dramatically damage the Modem	24
Figure 12: Recommended power supply connection on trucks.....	25
Figure 13: Functional architecture	35
Figure 14: RS232 Serial Link signals.....	37
Figure 15: Reset sequence diagram	41
Figure 16: Dimensioning diagram.....	44

PROLIMINARY

Caution

Information furnished herein by WAVECOM are accurate and reliable. However no responsibility is assumed for its use.

Please read carefully the safety recommendations given in chapter 9 for an application based on FASTRACK modem M1306B.

General information about WAVECOM and its range of products is available at the following internet address: <http://www.wavecom.com/>.

Trademarks

[®], WAVECOM[®], WISMO[®] and FASTRACK[®], and certain other trademarks and logos appearing on this document, are filed or registered trademarks of Wavecom S.A. in France or in other countries. All other company and/or product names mentioned may be filed or registered trademarks of their respective owners.

Copyright

This manual is copyrighted by WAVECOM with all rights reserved. No part of this manual may be reproduced in any form without the prior written permission of WAVECOM.

No patent liability is assumed with respect to the use of the information contained herein.

1 References

1.1 Reference Documents

- [1] Commands Interface Guide
WM_ASW_OAT_UGD_0010
- [2] Firmware upgrade procedure
WM_SW_GEN_UGD_001
- [3] GSM reference documents:
 - GSM 03.40,
 - GSM 03.45,
 - GSM 04.11,
 - GSM 04.21,
 - GSM 05.08,
 - GSM 07.01,
 - GSM 07.02,
 - GSM 07.05,
 - GSM 07.07.

1.2 Abbreviations

Abbreviation	Definition
AC	Alternative Current
ACM	Accumulated Call Meter
AT	ATtention (prefix for modem commands)
CLK	CLock
CMOS	Complementary Metal Oxide Semiconductor
CS	Coding Scheme
CTS	Clear To Send
dB	Decibel
dBc	Decibel relative to the Carrier power
dB _i	Decibel relative to an Isotropic radiator
dB _m	Decibel relative to one milliwatt
DC	Direct Current
DCD	Data Carrier Detect

Abbreviation Definition

DCE	Data Communication Equipment
DCS	Digital Cellular System
DSR	Data Set Ready
DTE	Data Terminal Equipment
DTMF	Dual Tone Multi-Frequency
DTR	Data Terminal Ready
EEPROM	Electrically Erasable Programmable Read-Only Memory
EFR	Enhanced Full Rate
E-GSM	Extended GSM
EMC	ElectroMagnetic Compatibility
EMI	ElectroMagnetic Interference
ESD	ElectroStatic Discharges
ETSI	European Telecommunications Standards Institute
FIT	Series of connectors (micro-FIT)
FR	Full Rate
FTA	Full Type Approval
GCF	Global Certification Forum
GND	Ground
GPIO	General Purpose Input Output
GPRS	General Packet Radio Service
GSM	Global System for Mobile communications
HR	Half Rate
I	Input
IEC	International Electrotechnical Commission
IMEI	International Mobile Equipment Identification
I/O	Input / Output
LED	Light Emitting Diode
MAX	MAXimum
ME	Mobile Equipment
MIC	MICrophone
Micro-Fit	Family of connectors from Molex
MIN	MINimum
MNP	Microcom Networking Protocol
MO	Mobile Originated
MS	Mobile Station

Abbreviation Definition

MT	Mobile Terminated
NOM	NOMinal
O	Output
Pa	Pascal (for speaker sound pressure measurements)
PBCCH	Packet Broadcast Control CHannel
PC	Personal Computer
PCL	Power Control Level
PDP	Packet Data Protocol
PIN	Personal Identity Number
PLMN	Public Land Mobile Network
PUK	Personal Unblocking Key
RF	Radio Frequency
RFI	Radio Frequency Interference
RI	Ring Indicator
RMS	Root Mean Square
RTS	Request To Send
RX	Receive
SIM	Subscriber Identification Module
SMA	SubMiniature version A RF connector
SMS	Short Message Service
SNR	Signal-to-Noise Ratio
SPL	Sound Pressure Level
SPK	SpeaKer
SRAM	Static RAM
TCP/IP	Transmission Control Protocol / Internet Protocol
TDMA	Time Division Multiple Access
TU	Typical Urban fading profile
TUHigh	Typical Urban, High speed fading profile
TX	Transmit
TYP	TYPical
VSWR	Voltage Stationary Wave Ratio

2 Packaging

2.1 Contents

The complete package contents of the FASTRACK modem M1306B consists of (See Figure 1):

- One packaging box (**item A**),
- One modem M1306B (**item B**),
- Two holding bridles (**item C**),
- One power supply cable with fuse integrated (**item D**),
- A short notice (**item E**) including:
 - A summary of the main technical features,
 - Safety recommendations,
 - EC declaration of conformity.



Figure 1: Complete package contents

2.2 Packaging box

The packaging box is a carton box (see Figure 2) with the following external dimensions:

- Width: 55 mm,
- Height: 60 mm,
- Length: 108 mm.

A packaging label is stuck on the cover of the packaging box and supports:

- The WAVECOM logo,
- The product reference (M1306B),
- The CE marking (CE0536),
- The 15-digit IMEI code.



Example of label for modem M1306B



Figure 2: Packaging box

The dimensions of the packaging label are:

- Height: 40 mm,
- Length: 65 mm.

2.3 Production sticker

A production sticker (see Figure 3) located at the back side of the modem gives the following information:

- The product reference (M1306B),
- the part number (WMxxxxx),
- the CE marking (CE0536),
- the 15-digit IMEI code,



Figure 3: Production sticker

Preliminary

3 General Presentation

3.1 Description

Description of the FASTRACK modem M1306B is given in the Figure Below.



Figure 4: FASTRACK modem M1306B general description

In addition, two holding bridles are provided to tighten the modem on a support.

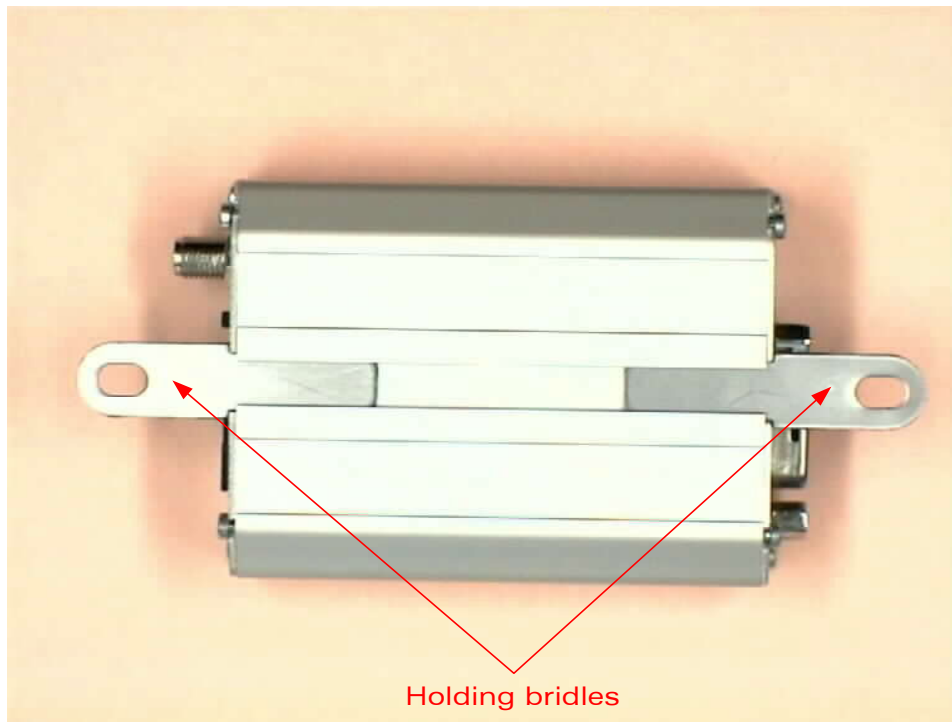

Figure 5: FASTRACK modem M1306B holding bridles

3.2 External connections

3.2.1 Connectors

3.2.1.1 Antenna connector

The antenna connector is a SMA type connector for a 50 Ω RF connection.

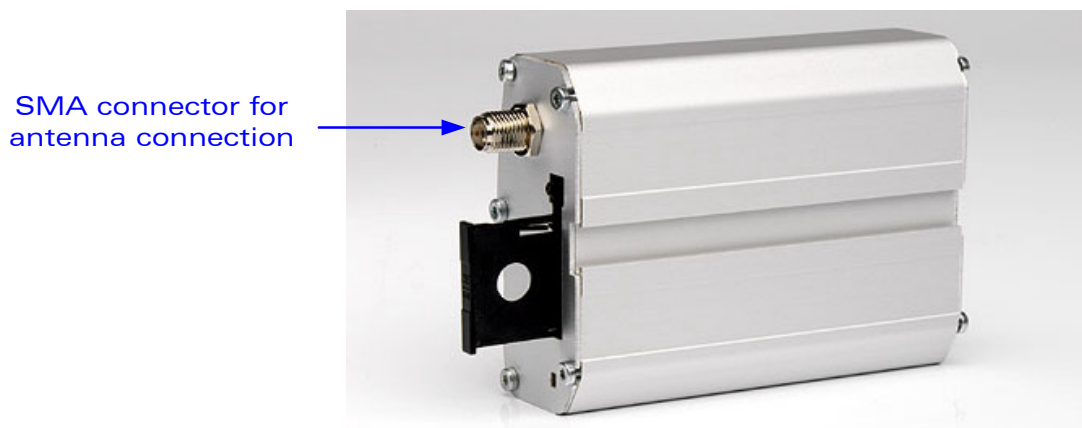

Figure 6: SMA connector for antenna connection

3.2.1.2 Power supply connector

The power supply connector is a 4-pin Micro FIT connector for:

- External DC Power Supply connection,
- GPIOs connection (2 General Purpose Input/Output signals available).



Figure 7: Power supply connector

Pin #	Signal	I/O	I/O type	Description	Comment
1	V+BATTERY	I	Power supply	Battery voltage input: <ul style="list-style-type: none"> ▪ 5.5 V Min. ▪ 13.2 V Typ. ▪ 32 V Max. 	High current
2	GND		Power supply	Ground	
3	GPIO4	I/O	CMOS/2X	General Purpose Input/output	
4	GPIO5	I/O	CMOS/2X	General Purpose Input/output	

3.2.1.3 Sub HD 15-pin connector

The Sub D high density 15-pin connector is used for:

- RS232 serial link connection,
- Audio lines (microphone and speaker) connection,
- BOOT and RESET signal connection.



Figure 8: Sub HD 15-pin connector

Pin #	Signal (CCITT / EIA)	I/O	I/O type	Description	Comment
1	CDCD/CT109	O	STANDARD RS232	RS232 Data Carrier Detect	
2	CTXD/CT103	I	STANDARD RS232	RS232 Transmit serial data	
3	BOOT	I	CMOS	Boot	Active low. Pull down through 1kΩ for Flash downloading
4	CMIC2P	I	Analog	Microphone positive line	
5	CMIC2N	I	Analog	Microphone negative line	
6	CRXD/CT104	O	STANDARD RS232	RS232 Receive serial data	
7	CDSR/CT107	O	STANDARD RS232	RS232 Data Set Ready	
8	CDTR/CT108-2	I	STANDARD RS232	RS232 Data Terminal Ready	
9	GND	-	GND	Ground	
10	CSPK2P	O	Analog	Speaker positive line	

Pin #	Signal (CCITT / EIA)	I/O	I/O type	Description	Comment
11	CCTS/CT106	O	STANDARD RS232	RS232 Clear To Send	
12	CRTS/CT105	I	STANDARD RS232	RS232 Request To Send	
13	CRI/CT125	O	STANDARD RS232	RS232 Ring Indicator	
14	RESET	I/O	Schmitt	Modem reset	Active low
15	CSPK2N	O	Analog	Speaker negative line	

3.2.2 Power supply cable

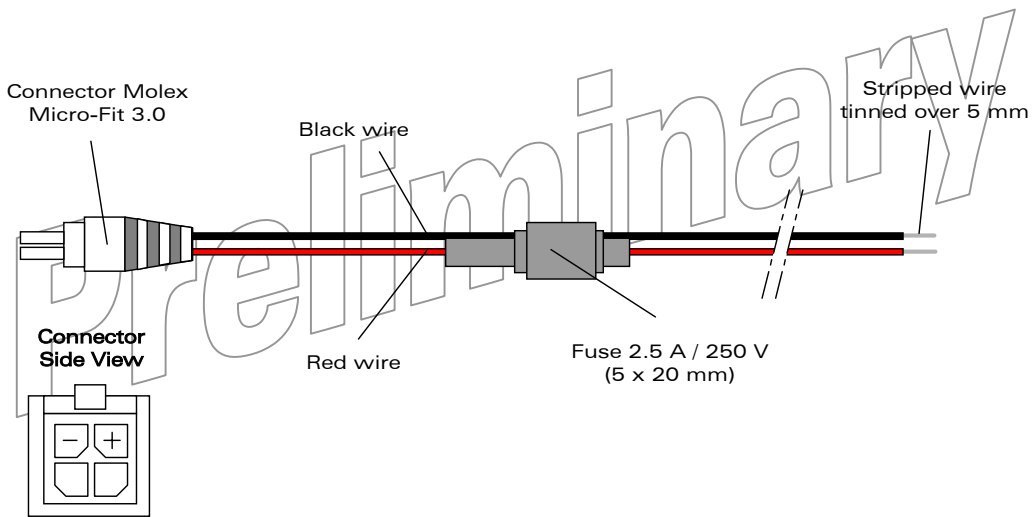

Figure 9: Power supply cable

Component	Characteristics
Micro-Fit connector 4-pin	Part number: MOLEX 43025-0400
Cable	Cable length: ~1.5 m
Wire	Core: tinned copper 24 x 0.2 mm
	Section: 0.75 mm ²

4 Basic features and services

Basic features of the modem and available services are summarized in the table below.

Features	GSM	DCS
Standard	900 MHz. E-GSM compliant. Output power: class 4 (2W). Fully compliant with ETSI GSM phase 2 + small MS.	1800 MHz Output power: class 1 (1W). Fully compliant with ETSI GSM phase 2 + small MS.
GPRS	Class 10. PBCCH support. Coding schemes: CS1 to CS4. Compliant with SMG31bis. Embedded TCP/IP stack (optional).	
Interfaces	RS232 (V.24/V.28) Serial interface supporting: <ul style="list-style-type: none"> ▪ Autoshutdown controlled by software (AT), ▪ Baud rate (bits/s): 300, 600, 1200, 2400, 4800, 9600, 19200, 38400, 57600, 115200, ▪ Autobauding (bits/s): 2400, 4800, 9600, 19200, 38400, 57600. 2 General Purpose Input/Output gates (GPIOs) available. 3 V SIM interface. AT command set based on V.25ter and GSM 07.05 & 07.07. OpenAT interface for embedded application.	
SMS	Text & PDU. Point to point (MT/MO). Cell broadcast.	
Data	Data circuit asynchronous. Transparent and Non Transparent modes. Up to 14.400 bits/s. MNP Class 2 error correction. V42.bis data compression.	
Fax	Automatic fax group 3 (class 1 and Class 2).	

Features	GSM	DCS
Audio	Echo cancellation Noise reduction Telephony. Emergency calls. Full Rate, Enhanced Full Rate and Half Rate operation (FR/EFR/HR). Dual Tone Multi Frequency function (DTMF).	
GSM supplem. services	Call forwarding. Call barring. Multiparty. Call waiting and call hold. Calling line identity. Advice of charge. USSD	
Other	DC power supply Real Time Clock with calendar Complete shielding	

For other detailed technical characteristics refer to chapter 8.

5 Using the modem

5.1 Getting started with the modem

5.1.1 Mounting the modem

To mount the modem on its support, bind it using the holding bridles as shown in the diagram below.

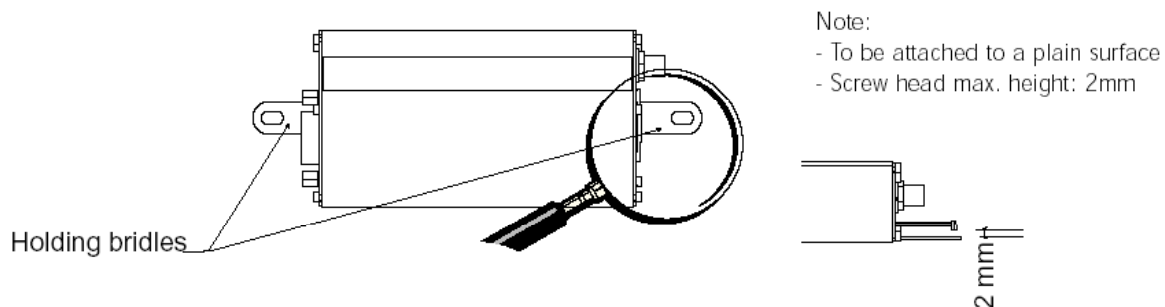

Figure 10: Modem mounting

For the drill template, refer to Figure 16.

5.1.2 Setting up the modem

To set up the modem, do the following operations:

- Press SIM card holder ejector with a sharp object (the tip of a pen for example).
- Insert the SIM card in the holder.
- Verify the SIM card fits in the holder properly.
- Insert the holder in the modem.
- Connect the antenna to the SMA connector.
- Connect both sides of the serial and control cable (15-pin Sub HD connector on the modem side).
- Connect the power supply cable to the external power supply source.

Note: for automotive application, it is recommended to connect the V+BATTERY line of the modem directly to the positive terminal of the battery.

- Plug the power supply cable into the modem and switch on the external power supply source.
- Now the modem is ready to work. Refer to paragraph 5.8 for some AT commands to configure the modem.

5.1.3 Checking the communication with the modem

- Connect the RS232 link between the DTE (port COM) and the modem (DCE).
- Configure the RS232 port of the DTE as follows:
 - Bits per second: **115.200 bps**,
 - Data bits: **8**,
 - Parity: **None**,
 - Stop bits: **1**,
 - Flow control: **hardware**.
- Using a communication software such as Hyperterminal, enter the **AT** command. The response of the modem must be **OK** displayed in the Hyperterminal window.
- If the communication cannot be established with the modem, do the following:
 - Check the RS232 connection between the DTE and the modem (DCE),
 - Check the configuration of the port COM used on the DTE.
- Example of AT commands which can be used after getting started the modem:
 - **AT+CGMI**: modem answer is "WAVECOM MODEM" when serial link is OK.
 - **AT+CPIN=xxxx**: to enter a PIN code xxxx (if activated).
 - **AT+CSQ**: to verify the received signal strength.
 - **AT+CREG?**: to verify the registration of the modem on the network.
 - **ATD<phone number>;**: to initiate a voice call.
 - **ATH**: to hang up (end of call).

For further information about these AT commands and their associated parameters, refer to document [1].

5.1.4 Resetting the modem

For resetting the modem, a hardware reset signal is available on pin 14 of the Sub HD 15-pin connector (RESET).

The reset of the modem is carried out when this pin is low for at least 500 μ s.

WARNING: This signal has to be considered as an emergency reset only. For further details about the reset of the modem, refer to paragraph 7.6.

5.2 Specific recommendations when using the modem on trucks

WARNING: the power Supply connection of the Fastrack Modem M1306B must NEVER be directly connected to the truck battery.

5.2.1 Technical constraints on trucks

All trucks have a circuit breaker outside of the cabin. This Circuit Breaker is used for safety reason: if a fire takes place in the trucks, on the wiring trunk for example, the driver may cut the current source to avoid any damage (explosion). This circuit breaker is connected to the truck ground, most often associated with the fuse box.

Most of truck circuit breakers do not cut the Positive Supply line of the battery but cut the ground line of the latter.

Because second hand installer prefer sometimes to connect directly the power supply on the battery rather than on the circuit breaker, the Fastrack modem may be damaged when starting the truck if the circuit breaker is switched Off (in this case the truck ground and the battery ground will be connected through the Modem as shown in the figure below).

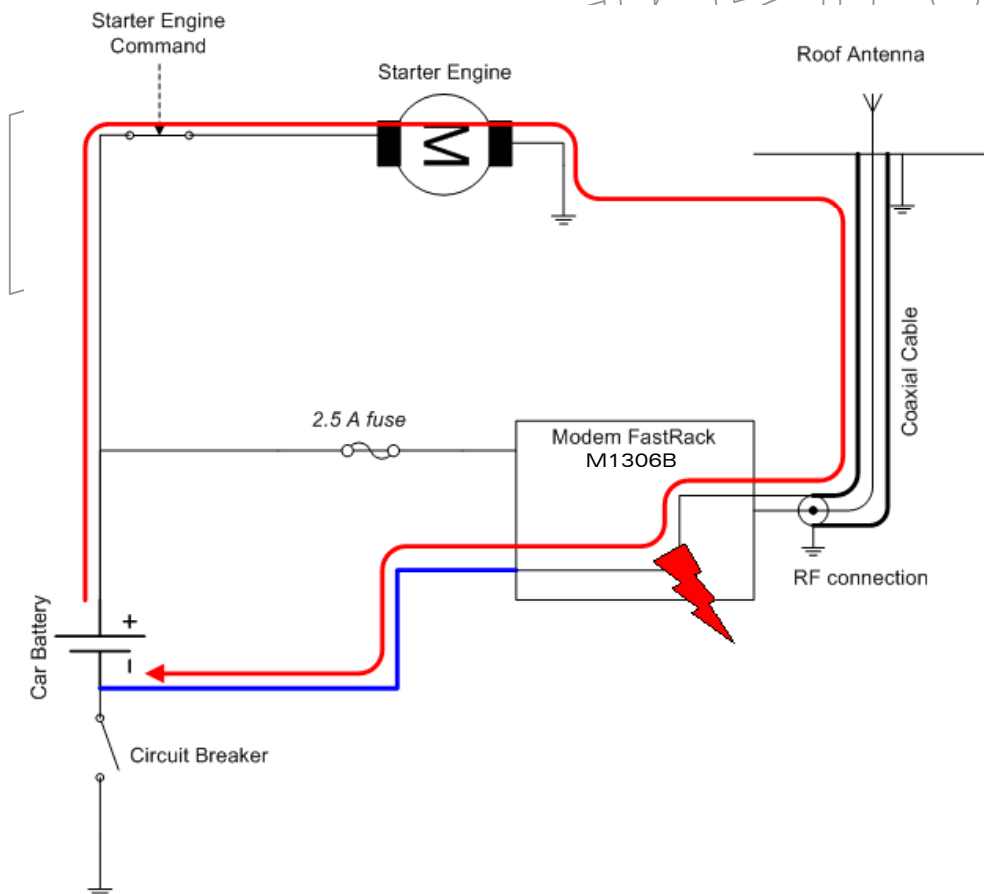

Figure 11: Example of electrical connection which may dramatically damage the Modem

Figure 11 gives an example of electrical connection which may dramatically damage the Modem when its ground connection is directly connected to the battery ground.

In this example, when the circuit breaker is switched off, the current flows through the MODEM and powers the electrical circuit of the truck (dashboard for example).

Furthermore, when the Starter Engine command will be used, it will destroy the cables or the Modem.

Since the internal tracks are not designed to support high current (up to 60 A when starting the truck), they will be destroyed.

5.2.2 Recommended Power Supply connection on trucks

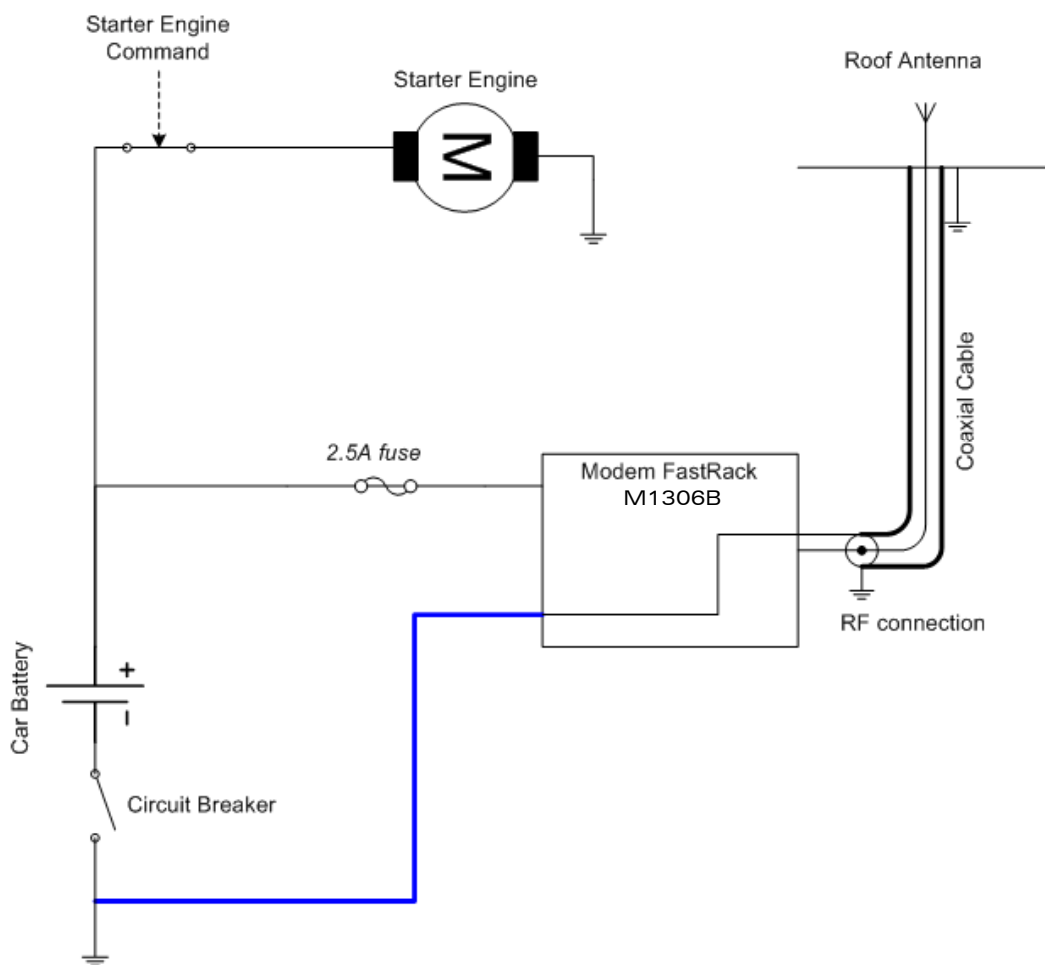

Figure 12: Recommended power supply connection on trucks

Figure 12 gives the recommended power supply connection where the ground connection of the modem is not directly connected to the battery but is connected after the Circuit Breaker (on the truck ground or the fusebox).

5.3 Operational status of the modem

The operational status of the modem is given by the status of the green LED located on the front panel of the modem.

The table below gives the meaning of the various statuses available.

Table 1: Operational status of the modem

LED Status	LED light activity	Modem status
ON	LED ON permanent	Modem is switched on but not registered on the network
	LED Flashing slowly	Modem is switched on and registered on the network, and its activity status is idle mode
	LED Flashing rapidly	Modem is switched on and registered on the network, and a communication is in progress
OFF	LED OFF	Modem is switched off.

5.4 Echo function disabled

If no echo is displayed when entering an AT command, that means:

- The "local echo" parameter of your communication software (such as Hyperterminal) is disabled,
- The echo function of the modem is disabled.

To enable the echo function of the modem, enter the **ATE1**.

When sending AT commands to the modem by using a communication software, it is recommended:

- To disable the "local echo" parameter of your communication software (such as Hyperterminal),
- To enable the echo function of the modem (**ATE1** command).

In a Machine To Machine communication with the modem, it is recommended to disable the echo function of the modem (**ATE0** command) in order to avoid useless CPU processing.

For further information about **ATE0** and **ATE1** commands, refer to document [1].

5.5 Verifying the received signal strength

The Fastrack modem establishes a call only if the received signal is sufficiently strong.

To verify the received signal strength, do the following operations:

- Using a communication software such as Hyperterminal, enter the AT command **AT+CSQ**.
The response returned has the following format:
+CSQ: <rssi>, <ber> with:
 - **<rssi>** = received signal strength indication,
 - **<ber>** = channel bit error rate.
- Verify the **<rssi>** value returned which interpretation is given in the table below.

Table 2: Values of received signal strength

Value of received signal strength indication (<rssi>)	Interpretation of the received signal strength
0 - 10	Insufficient(*)
11 - 31	Sufficient(*)
Greater than 99	No measure available

(*) Based on general observations.

For further information about AT commands refer to document [1].

5.6 Checking the pin code status

To check that the pin code has been entered, use a communication software such as Hyperterminal, then enter **AT +CPIN?** command.

The table below gives the main responses returned:

AT +CPIN response (*)	Interpretation
+CPIN: READY	Code PIN has been entered
+CPIN: SIM PIN	Code PIN has not been entered

(*)For further information about the other possible responses and their meaning refer to document [1].

5.7 Verifying the network registration of the modem

1. Make sure a valid SIM card has been previously inserted in the SIM card holder of the modem.
2. Using a communication software such as Hyperterminal, enter the following AT commands:
 - a. **AT+CPIN=xxxx** to enter PIN code xxxx.
 - b. **AT+CREG?** To ascertain the registration status.

The format of the returned response is the following:

+CREG: <mode>, <stat> with:

- o **<mode>** = unsolicited registration message configuration,
- o **<stat>** = registration state.

3. Verify the state of registration according the returned value given in the table below.

Table 3: Values of network registration

Returned Value (*) <mode>, <stat>	Network registration
+CREG: 0,0	No (not registered)
+CREG: 0,1	Yes (registered, home network)
+CREG: 0,5	Yes (registered, roaming)

(*)For further information about the other returned values and their meaning refer to document [1].

If the modem is not registered, perform the following procedure:

- Check the connection between the modem and the antenna.
- Verify the signal strength to determine the strength of the received signal (refer to paragraph 5.4).

5.8 Main AT commands for the modem

The table below reminds the main AT commands required for getting started the modem.

For other AT commands available or further information about the AT commands, refer to document [1].

Table 4: Main usual AT commands for the modem

Description	AT commands	Modem's response	Comment
Enter PIN Code	AT+CPIN=xxxx (xxxx = PIN code)	OK	PIN Code accepted.
		+CME ERROR: 16	Incorrect PIN Code (with +CMEE = 1 mode).
		+CME ERROR: 3	PIN code already entered (with +CMEE = 1 mode).
Network registration checking	AT+CREG?	+CREG: 0,1	Modem registered on the network.
		+CREG: 0,2	Modem not registered on the network, registration attempt.
		+CREG: 0,0	Modem not registered on the network, no registration attempt.
Receiving an incoming call	ATA	OK	Answer the call.
Initiate a call	ATD<phone number>; (Don't forget the « ; » at the end for « voice » call)	OK	Communication established.
		+CME ERROR: 11	PIN code not entered (with +CMEE = 1 mode).
		+CME ERROR: 3	AOC credit exceeded or a communication is already established.
Initiate an emergency call	ATD112; (Don't forget the « ; » at the end for « voice » call)	OK	Communication established.
Communication loss		NO CARRIER	
Hang up	ATH	OK	
Store the parameters in EEPROM	AT&W	OK	The configuration settings are stored in EEPROM.

5.9 Firmware upgrade procedure

The firmware upgrade procedure is used to update the firmware embedded into the FASTRACK modem.

That procedure consists in downloading the firmware into internal memories through the RS232 serial link available on the SUB-D 15-pin connector.

Refer to document [2] for a detailed description of that procedure.

Preliminary

6 Troubleshooting

This section of the document describes possible problems encountered when using the Fastrack modem and their solutions.

To review other troubleshooting information, refer the 'FAQs' (Frequently Asked Questions) page at www.wavecom.com or use the following link:

<http://www.wavecom.com/support/faqs.php>

6.1 No communication with the modem through the serial link

If the Fastrack modem does not answer to AT commands through the serial link, refer to the table below for possible causes and solutions.

Table 5: Solutions for no connection with modem through serial link

If the modem returns...	Then ask	Action
Nothing	Is the modem powered correctly?	Make sure the external power supply is connected to the modem and provides a voltage in the range of 5.5 V to 32 V.
	Is the serial cable connected at both sides?	Check the serial cable connection
	Does the serial cable follow correctly pin assignment shown in paragraph 3.2.1.3.	Connect the cable by following pin assignment given in paragraph 3.2.1.3.
Nothing or non significant characters	Is the communication program properly configured on PC?	Ensure the setting of the communication program is fit to setting of modem. Modem factory setting is: Data bits = 8 Parity = none Stop bits = 1 Baud = 115.200 kbps. Flow control = hardware
	Is there another program interfering with the communication program (i.e. Conflict on communication port access)	Close the interfering program.

6.2 Receiving "ERROR" message

The modem returns an "ERROR" message (in reply to an AT command) in the following cases:

- AT command syntax is incorrect: then check the command syntax (refer to document [1]),
- AT command syntax is correct but transmitted with wrong parameters:
 - Enter the *AT +CMEE=1* command in order to enable the mechanism allowing to get the Mobile Equipment error code instead of simply "ERROR" message,
 - Enter again the AT command which previously caused the reception of "ERROR" message in order to get the Mobile Equipment error code.

When the mechanism allowing to get the Mobile Equipment error code is enable, the response of the modem in case of error is the following:

- Either *+CME ERROR: <error result code>*,
- Or *+CMS ERROR: <error result code>*.

Refer to document [1] for error result code description and further details about the *AT +CMEE* command.

Note: It is strongly recommended to systematically enable the mechanism allowing to get the Mobile Equipment error code (enter *AT +CMEE=1* command).

6.3 Receiving "NO CARRIER" message

If the modem returns a "NO CARRIER" message upon an attempted call (voice or data), then refer to the table below for possible causes and solutions.

Table 6: Solutions for "NO CARRIER" message

If the modem returns...	Then ask...	Action...
"NO CARRIER"	Is the received signal strong enough?	Refer to paragraph 5.4 to verify the strength of the received signal.
	Is the modem registered on the network?	Refer to paragraph 5.7 to verify the registration.
	Is the antenna properly connected?	Refer to paragraph 8.2.6.3 for antenna requirements.
"NO CARRIER" (when trying to issue a voice communication)	Is the semicolon (;) entered immediately after the phone number in the AT command?	Ensure that the semicolon (;) is entered immediately after the phone number in the AT command. e.g. ATD#####;

If the modem returns...	Then ask...	Action...
"NO CARRIER" (when trying to issue a data communication)	Is the SIM card configured for data / fax calls?	Configure the SIM card for data / fax calls (Ask your network provider if necessary).
	Is the selected bearer type supported by the called party?	Ensure that the selected bearer type is supported by the called party.
	Is the selected bearer type supported by the network?	Ensure that the selected bearer type is supported by the network. If no success, try bearer selection type by AT command: AT+CBST=0,0,3

If the Fastrack modem returns a "NO CARRIER" message , you can have the **extended error code** by using AT command **AT+CEER**. Refer to the table below for interpretation of **extended error code**.

Table 7: Interpretation of extended error code

Error Code	Diagnostic	Hint
1	Unallocated phone number	Not applicable.
16	Normal call clearing	
17	User busy	
18	No user responding	
19	User alerting, no answer	
21	Call rejected	
22	Number changed	
31	Normal, unspecified	
50	Requested facility not subscribed	Check your subscription (data subscription available?).
68	ACM equal or greater than ACMmax	Credit of your pre-paid SIM card expired.
252	Call barring on outgoing calls	Not applicable.
253	Call barring on incoming calls	

Error Code	Diagnostic	Hint
3, 6, 8, 29, 34, 38, 41, 42, 43, 44, 47, 49, 57, 58, 63, 65, 69, 70, 79, 254	Network causes	See AT commands manual for further details or call network provider.

Note: For all other codes, and/or details, see AT commands documentation.

Preliminary

7 Functional description

7.1 Architecture

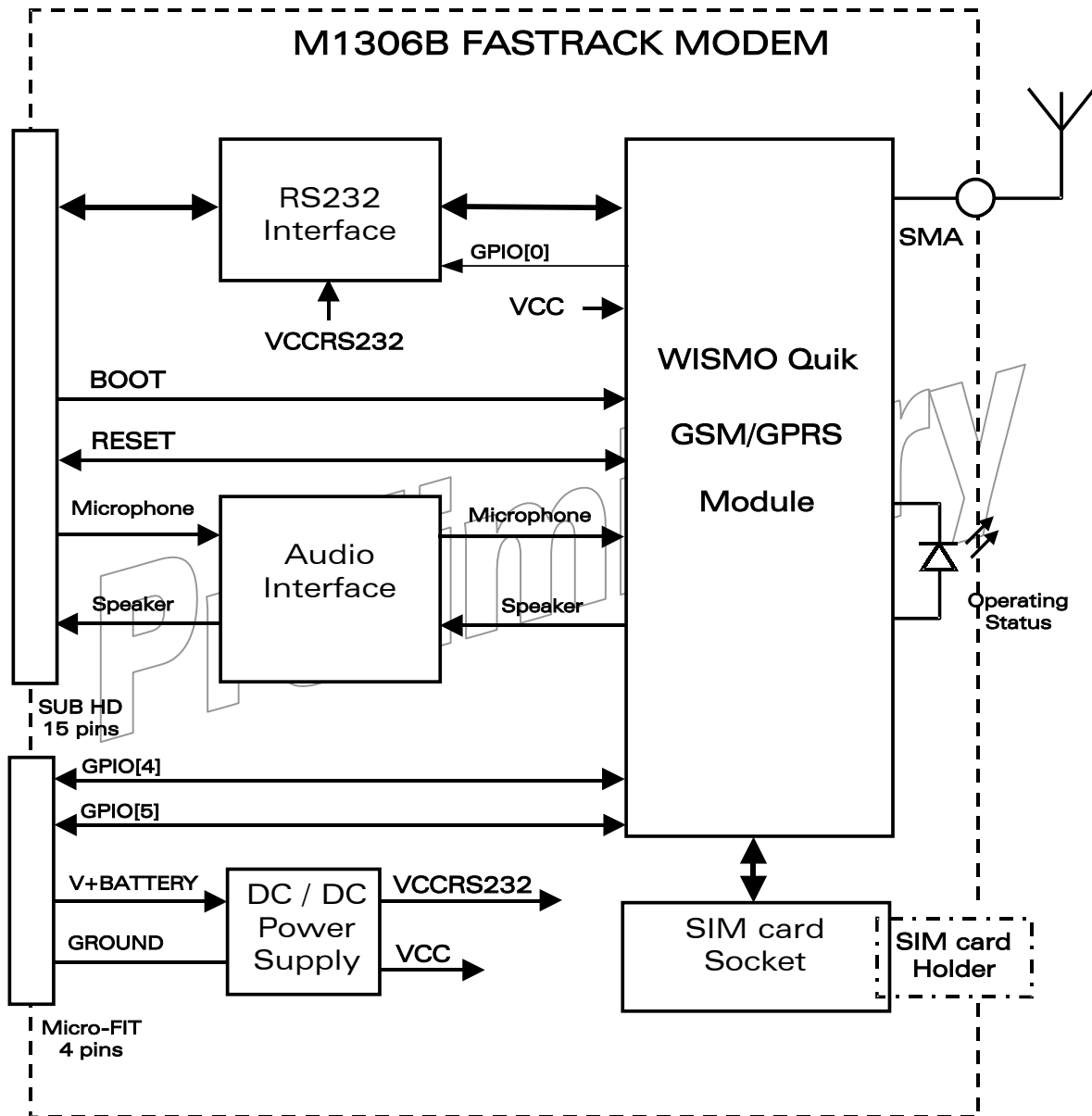

Figure 13: Functional architecture

7.2 Power supply

7.2.1 General presentation

The modem is supplied by an external DC voltage (V+BATTERY) from +5.5 V to +32 V.

Main regulation is made with an internal DC/DC converter in order to supply all the internal functions with a DC voltage.

Correct operation of the FASTRACK modem in communication mode is not guaranteed if input voltage (V+BATTERY) falls below 5.5 V.

7.2.2 Protections

The modem is protected by a 2.5 A / 250 V fuse directly bonded on the power supply cable.

The modem is also protected against voltage over +32 V.

When input voltages exceed +32 V, the supply voltage is disconnected in order to protect the internal electronic components from an overvoltage.

Filtering guarantees:

- EMI/RFI protection in input and output,
- Signal smoothing.

Preliminary

7.3 RS232 serial link

7.3.1 General presentation

The RS232 interface performs the voltage level adaptation (V24/CMOS ↔ V24/V28) between the internal WISMO module (DCE) and the external world (DTE).

The RS232 interface is internally protected (by ESD protection) against electrostatic surges on the RS232 lines.

Filtering guarantees:

- EMI/RFI protection in input and output,
- Signal smoothing.

Signals available on the RS232 serial link are:

- TX data (CT103/TX),
- RX data (CT104/RX),
- Request To Send (CT105/RTS),
- Clear To Send (CT106/CTS),
- Data Terminal Ready (CT108-2/DTR),
- Data Set Ready (CT107/DSR),
- Data Carrier Detect (CT109/DCD),
- Ring Indicator (CT125/RI).

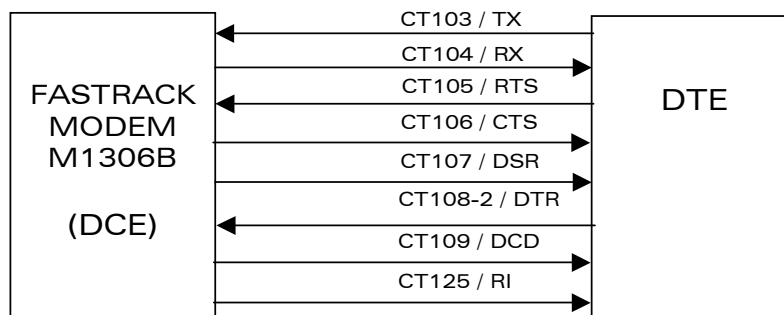

Figure 14: RS232 Serial Link signals

RS232 interface has been designed to allow a certain flexibility in the use of the serial interface signals. However, the use of TX, RX, CTS and RTS signals is mandatory which is not the case for DTR, DSR, DCD and RI signals which can be not used.

7.3.2 Green idle power saving mode

This is a power saving mode which is automatically enabled inside the modem when there is no load on the RS232 serial link (no connection to a DTE).

7.3.3 Autoshutdown facility

The autoshutdown is a facility that permits to reduce the power consumption of the internal RS232 transceiver device. While shutdown facility is enabled:

- All Internal RS232 transmitters are disabled to reduce the power consumption,
- All internal RS232 receivers are shut down except for CT103/TX receiver which can alert the WISMO module in order to disable the shutdown facility .

This autoshutdown facility is controlled through one of the WISMO Quik module General Purpose I/O (GPIO), driven through AT Commands:

1. to make sure that GPIO control is effective, it must be configured as an output using **AT+WIOM** command: **AT+WIOM=0,**
2. to enable or disable autoshutdown, use **AT+WIOW** command to drive GPIO:
 - GPIO0 = 0: autoshutdown disable (**AT+WIOW=0,0,**
 - GPIO0 = 1: autoshutdown enable (**AT+WIOW=0,1,**

7.3.4 Autobauding mode

The autobauding mode allows the modem to detect the baud rate used by the DTE connected to the RS232 serial link.

Autobauding mode is controlled by AT commands. See [1] for details about this function.

7.3.5 Pin description

Signal	Sub HD connector Pin number	I/O	I/O type RS232 STANDARD	Description
CTXD/CT103	2	I	TX	Transmit serial data
CRXD/CT104	6	O	RX	Receive serial data
CRTS/CT105	12	I	RTS	Request To Send
CCTS/CT106	11	O	CTS	Clear To Send
CDSR/CT107	7	O	DSR	Data Set Ready
CDTR/CT108-2	8	I	DTR	Data Terminal Ready
CDCD/CT109	1	O	DCD	Data Carrier Detect
CRI/CT125	13	O	RI	Ring Indicator
CT102/GND	9			Ground

7.4 General Purpose Input/Output (GPIO)

The FASTRACK modem M1306B provides two General Purpose Input / Output lines available for external use: GPIO4 and GPIO5.

These GPIOs can be controlled by AT commands:

- **AT+WIOW** for a write access to the GPIO value when the GPIO is used as an output,
- **AT+WIOR** for a read access to the GPIO value when the GPIO is used as an input.

Refer to document [1] for further information about AT commands.

After reset, both GPIOs are configured as inputs. The **AT+WIOM** command has to be used to change this configuration (refer to document [1] for further details).

Pin description

Signal	Power Supply connector (4-pin Micro-Fit)	I/O	I/O type	Description
GPIO4	3	I/O	CMOS / 2X	General Purpose I/O
GPIO5	4	I/O	CMOS / 2X	General Purpose I/O

Note: the power supply cable may need to be modified due to the GPIO signals (GPIO4 & GPIO5) available on the 4-pin Micro-FIT connector of the modem.

7.5 BOOT

This signal must not be connected. Its use is strictly reserved to WAVECOM or competent retailers.

7.6 RESET

7.6.1 General presentation

This signal is used to force a reset procedure by providing low level during at least 500 μ s.

This signal has to be considered as an emergency reset only. A reset procedure is automatically driven by an internal hardware during the power-up sequence.

This signal can also be used to provide a reset to an external device. It then behaves as an output. If no external reset is necessary this input can be left open, if used (emergency reset), it has to be driven by an open collector or an open drain output:

- RESET pin 14 = 0, for Modem Reset,
- RESET pin 14 = 1, for normal mode.

Pin description

Signal	Sub HD 15-Pin connector Pin number	I/O	I/O type	Description
RESET	14	I/O	SCHMITT	Modem Reset

Additional comments on RESET:

The RESET process is activated either by the external RESET signal or by an internal signal (coming from a RESET generator). This automatic reset is activated at Power-up.

The modem remains in RESET mode as long as the RESET signal is held low.

This signal should be used only for "emergency" reset.

A software reset is always preferred to a hardware reset.

7.6.2 Reset sequence

To activate the « emergency » reset sequence, the RESET signal has to be set to low for 500 μ s minimum.

As soon as the reset is complete, the AT interface answers « OK » to the application. For this, the application has to send **AT**.

If the application manages hardware flow control, the AT command can be sent during the initialisation phase. Another solution is to use the **AT+WIND** command to get an unsolicited status from the modem.

For further details, refer to AT commands documentation [1].

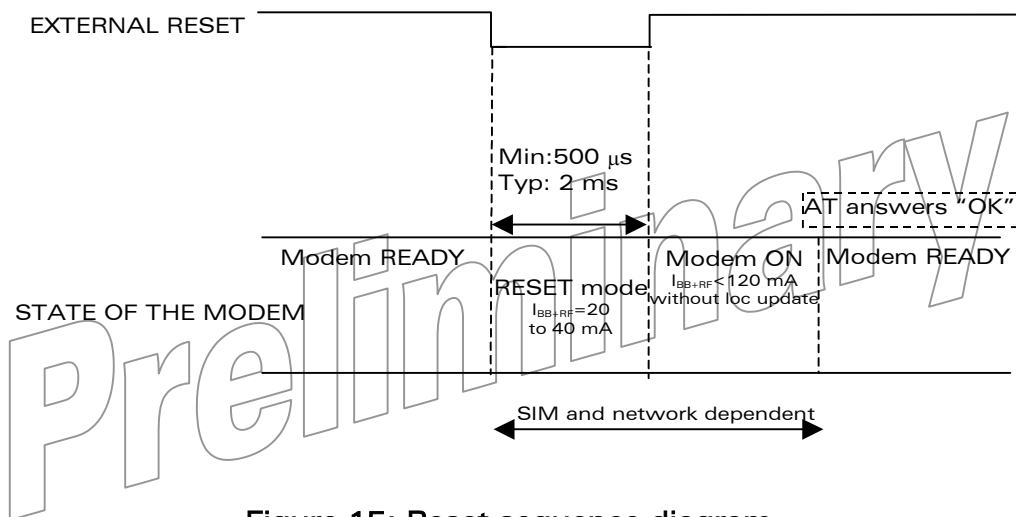

Figure 15: Reset sequence diagram

7.7 Audio

Audio interface is a standard one for connecting a phone handset.

Echo cancellation and noise reduction features are also available to improve the audio quality in case of hands-free application.

7.7.1 Microphone inputs

The microphone inputs are differential ones in order to reject common mode noise and TDMA noise.

They already include the convenient biasing for an electret microphone (0.5 mA and 2 Volts) and are ESD protected.

This electret microphone can be directly connected to these inputs allowing an easy connection to a handset.

The impedance of the microphone has to be around 2 k Ω .

AC coupling is already embedded in the modem.

The gain of the microphone inputs is internally adjusted and can be tuned from 30 dB to 51 dB using an **AT +VGT** command (refer to AT commands documentation [1]).

Pin description

Signal	Sub D 15-pin Pin #	I/O	I/O type	Description
CMIC2P	4	I	Analog	Microphone positive input
CMIC2N	5	I	Analog	Microphone negative input

7.7.2 Speaker outputs

This connection is differential to reject common mode noise and TDMA noise.

Speaker outputs are connected to internal push-pull amplifiers and can be loaded down to 150 Ohms and up to 1 nF (see details in table *Speaker gain vs Max output voltage*). These outputs can be directly connected to a speaker.

The output power can be adjusted by step of 2 dB. The gain of the speaker outputs is internally adjusted and can be tuned using an **AT +VGR** command (refer to AT commands documentation [1]).

Pin description

Signal	Sub D 15-pin Pin #	I/O	I/O type	Description
CSPK2P	10	O	Analog	Speaker positive output
CSPK2N	15	O	Analog	Speaker negative output

8 Technical characteristics

8.1 Mechanical characteristics

Dimensions	73 x 54.5 x 25.5 mm (excluding connectors)
Overall Dimension	88 x 54.5 x 25.5 mm
Weight	≈ 80 grams (modem only) < 120 grams (modem + bridles + power supply cable)
Volume	101.5 cm ³
Housing	Aluminium profiled

The next page gives the dimensioning diagram of the modem including the clearance areas to take into account for the installation of the modem.

Preliminary

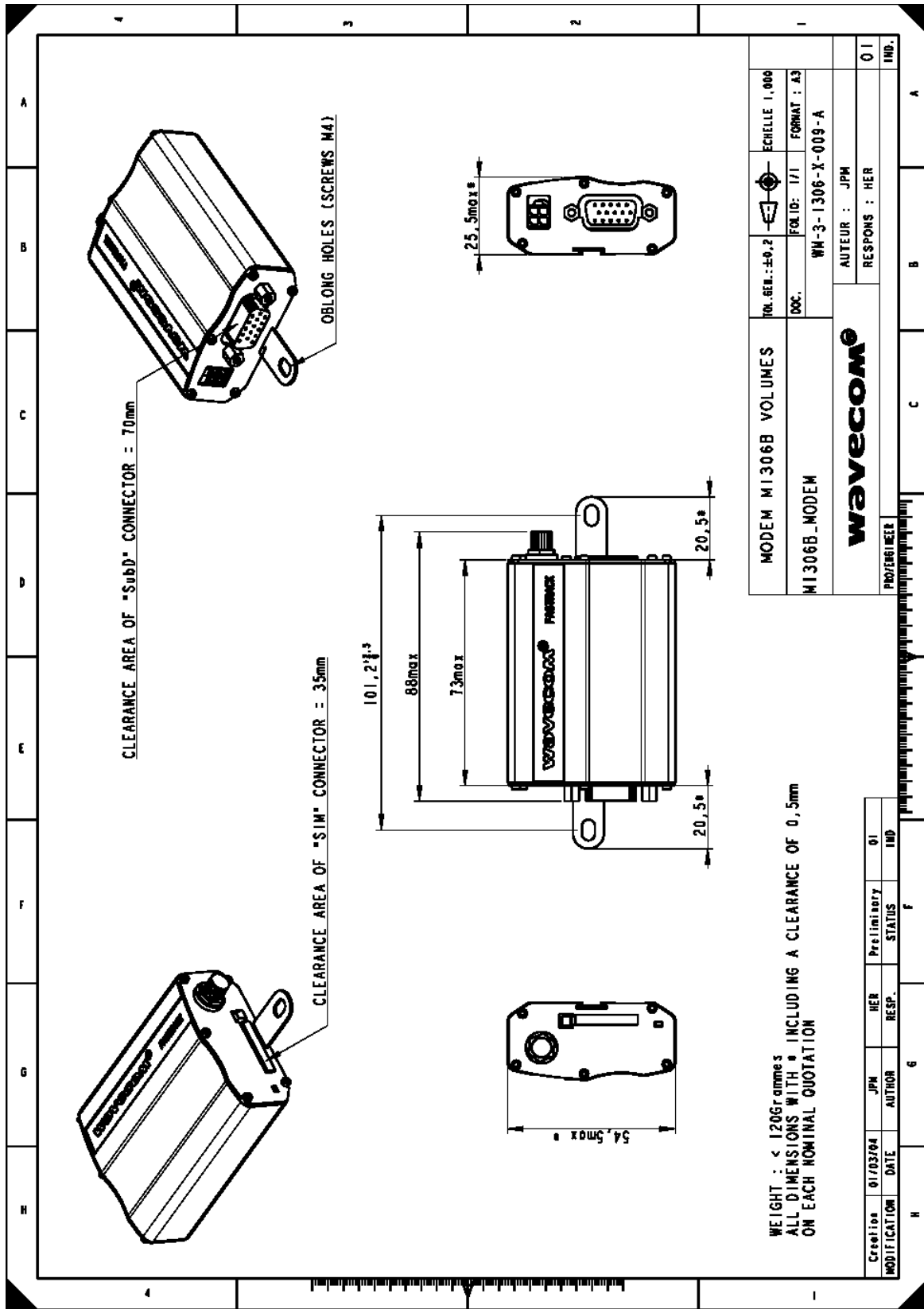

Figure 16: Dimensioning diagram

8.2 Electrical characteristics

8.2.1 Power supply

Table 8: Electrical characteristics

Operating Voltage ranges	5.5 V to 32 V DC (GSM or DCS or GPRS).
Maximum current	480 mA Average at 5.5V. 1.7 A Peak at 5.5 V.

Note: the modem is permanently powered once the power supply is connected. The following table describes the consequences of overvoltage and undervoltage with the Fastrack Modem.

Table 9: Effects of power supply defect

If the voltage :	Then:
▪ falls below 5.5 V	▪ The GSM communication is not guaranteed.
▪ Voltage over 32 V (Transient peaks)	▪ The modem guarantees its own protection.
▪ Voltage over 32 V (continuous overvoltage)	▪ Protection of the modem by the fuse (the supply voltage is disconnected).

The following table provides information on power consumption of the Fastrack modem, assuming an operating temperature of +25 °C and using a 3 V SIM card.

Table 10: Power consumption

Power Consumption in E-GSM 900/DCS 1800 MHz - GPRS class 10		E-GSM 900	DCS 1800
Input Peak Supply Current During 2TX bursts @Pcl5	@ 5.5 V	1500 mA (average)	1420 mA (average)
Input average supply current in communication mode Average 3Rx/2Tx @Pcl5	@ 5.5 V	341 mA RMS	324 mA RMS
Input Peak Supply Current During 1TX bursts @Pcl5	@ 5.5 V	1780 mA (average)	1670 mA (average)
Input average supply current in communication mode Average 1Rx/1Tx @Pcl5	@ 5.5 V	200 mA RMS	189 mA RMS
Input average supply current in idle mode with no RS232 link	@ 5.5 V	14 mA	14 mA
Input average supply current in idle mode with active RS232 link	@ 5.5 V	31 mA	31 mA
Input average supply current in idle mode with autoshutdown	@ 5.5 V	14 mA	14 mA

The power consumption might vary by 5 % over the whole operating temperature range (-20 °C to +55 °C).

8.2.2 Audio interface

The audio interface is available through the Sub HD 15-pin connector.

Audio parameters	Min	Typ	Max	Unit	Comments
Microphone input current @2 V/2 k Ω		0.5		mA	
Absolute microphone input voltage			100	mVpp	AC voltage
Speaker output current 150 Ω //1 nF		16		mA	
Absolute speaker impedance	32	50		Ω	
Impedance of the speaker amplifier output in differential mode			1	Ω	+/-10 %

Microphone inputs internal audio filter characteristics

Frequency	Gain
0-150 Hz	< -22 dB
150-180 Hz	< -11 dB
180-200 Hz	< -3 dB
200-3700 Hz	0 dB
>4000 Hz	< -60 dB

Recommended characteristics for the microphone:

Feature	Value
Type	Electret 2 V / 0.5 mA
Impedance	Z = 2 k Ω
Sensitivity	-40 dB to -50 dB
SNR	> 50 dB
Frequency response	compatible with the GSM specifications

Recommended characteristics for the speaker:

Feature	Value
Type	10 mW, electro-magnetic
Impedance	Z = 32 to 50 Ω
Sensitivity	110 dB SPL min. (0 dB = 20 μ Pa)
Frequency response	compatible with the GSM specifications

8.2.3 General Purpose Input/output

Both digital GPIO4 and GPIO5 comply with 3 Volts CMOS.

Table 11: Operating conditions

Parameter	I/O type	Min	Max	Condition
V_{IL}	CMOS	-0.5 V	0.8 V	
V_{IH}	CMOS	2.1 V	3.0 V	
V_{OL}	2X		0.2 V	$I_{OL} = -2 \text{ mA}$
V_{OH}	2X	2.6 V		$I_{OH} = 2 \text{ mA}$

8.2.4 SIM interface

Table 12: SIM card characteristics

SIM card	3 V only
----------	----------

8.2.5 RESET Signal

Table 13: Electrical characteristics

Parameter	Min	Max	Unit
Input Impedance (R)	4.7		k Ω
Input Impedance (C)		10	nF

Table 14: Operating conditions

Parameter	Min	Max	Condition
* V_{T-}	1.1 V	1.2 V	
* V_{T+}	1.7 V	1.9 V	
V_{OL}		0.4 V	$I_{OL} = -50 \mu\text{A}$
V_{OH}	2.0 V		$I_{OH} = 50 \mu\text{A}$

* V_{T-}, V_{T+} : Hysteresis thresholds

8.2.6 RF characteristics

8.2.6.1 Frequency ranges

Table 15: Frequency ranges

Characteristic	E-GSM 900	DCS 1800
Frequency TX	880 to 915 MHz	1710 to 1785 MHz
Frequency RX	925 to 960 MHz	1805 to 1880 MHz

8.2.6.2 RF performances

RF performances are compliant with the ETSI recommendation GSM 05.05.
The RF performances for receiver and transmitter are given in the table below.

Table 16: Receiver and transmitter RF performances

Receiver	
E-GSM900 Reference Sensitivity	-104 dBm Static & TUHigh
DCS1800 Reference Sensitivity	-102 dBm Static & TUHigh
Selectivity @ 200 kHz	> +9 dBc
Selectivity @ 400 kHz	> +41 dBc
Linear dynamic range	63 dB
Co-channel rejection	>= 9 dBc
Transmitter	
Maximum output power (E-GSM 900) at ambient temperature	33 dBm +/- 2 dB
Maximum output power (DCS1800) at ambient temperature	30 dBm +/- 2 dB
Minimum output power (E-GSM 900) at ambient temperature	5 dBm +/- 5 dB
Minimum output power (DCS1800) at ambient temperature	0 dBm +/- 5 dB

8.2.6.3 External antenna

The external antenna is connected to the modem via the SMA connector.
The external antenna must fulfill the characteristics listed in the table below.

Table 17: External antenna characteristics

Antenna frequency range	Dual-band GSM 900/DCS 1800 MHz
Impedance	50 Ohms nominal
DC impedance	0 Ohm
Gain (antenna + cable)	0 dBi
VSWR (antenna + cable)	-10 dB

Note: refer to chapter 10 for recommended antenna.

Preliminary

8.3 Environmental characteristics

To ensure the proper operation of the FASTRACK Modem, the temperature of the environment must be within a specific range as described in the table below.

Table 18: Ranges of temperature

Operating temperature range	-20 °C to +55 °C
Transportation temperature range	-40 °C to +70°C
Storage temperature range	-25 °C to +70°C

The detailed climatic and mechanics standard environmental constraints applicable to the modem are listed in the table below:

Table 19: Environmental standard constraints

M1306B Modem		ENVIRONMENTAL CLASSES					
Type of test	Standards	STORAGE Class 1.2		TRANSPORTATION Class 2.3		OPERATING (port use) Class 7.3	
Cold	IEC 68-2.1 Ab test	-25 °C	72 h	-40 °C	72 h	-20 °C	16 h
Dry heat	IEC 68-2.2 Bb test	+70 °C	72 h	+70 °C	72 h	+55 °C	16 h
Change of temperature	IEC 68-2.14 Na/Nb test			-40 °/+30 °C 5 cycles t1=3 h		-20 °/+30 °C 3 cycles t1=3 h	
Damp heat cyclic	IEC 68-2.30 Db test	+30 °C	2 cycles 90 %-100 % RH variant1	+40 °C	2 cycles 90 %-100 % RH variant1	+40 °C	2 cycles 90 %-100 % RH variant1
Damp heat	IEC 68-2.56 Cb test	+30 °C	4 days	+40 °C	4 days	+40 °C	4 days
Sinusoidal vibration	IEC 68-2.6 Fc test		5-62 Hz: 5 mm/s 62-200 Hz: 2 m/s ² 3x5 sweep cycles				
Random vibration Wideband	IEC 68-3.36 Fdb test			5-20 Hz: 0.96 m ² /s ³ 20-500 Hz: -3 dB/oct 3 x 10 min		10-12 Hz: 0.96 m ² /s ³ 12-150 Hz: -3 dB/oct 3 x 30 min	

8.4 Conformity

The complete product complies with the essential requirements of article 3 of R&TTE 1999/5/EC Directive and satisfied the following standards:

Domain	Applicable standard
Safety standard	EN 60950,
Efficient use of the radio frequency spectrum	EN 301 419-1 / EN 301 511,
EMC	EN 301 489-1 / EN 301 489-7.
Global Certification Forum – Certification Criteria	GCF-CC V3.13

8.5 Protections

8.5.1 Power supply

The modem is protected by a 2.5 A / 250 V fuse directly bonded on the power supply cable.

The model of fuse used is: **FSD 2.5 A / 250 V FAST-ACTING.**

8.5.2 Overvoltage

The modem is protected against voltage over +32 V.

When input voltages exceed +32 V, the supply voltage is disconnected in order to protect the internal electronic components from an overvoltage.

8.5.3 ESD

The modem withstands ESD according to IEC 1000-4-2 requirements for all accessible parts of the modem except the RF part:

- 10 kV of air discharge,
- 5 kV of contact discharge.

8.5.4 Miscellaneous

Filtering guarantees:

- EMI/RFI protection in input and output,
- Signal smoothing.

9 Safety recommendations

9.1 General Safety

It is important to follow any special regulations regarding the use of radio equipment due in particular to the possibility of radio frequency (RF) interference. Please follow the safety advice given below carefully.

Switch OFF your GSM Modem:

- When in an aircraft. The use of cellular telephones in an aircraft may endanger the operation of the aircraft, disrupt the cellular network and is illegal. Failure to observe this instruction may lead to suspension or denial of cellular telephone services to the offender, or legal action or both,
- When at a refueling point,
- When in any area with a potentially explosive atmosphere which could cause an explosion or fire,
- In hospitals and any other place where medical equipment may be in use.

Respect restrictions on the use of radio equipment in:

- Fuel depots,
- Chemical plants,
- Places where blasting operations are in progress,
- Any other area where signalization reminds that the use of cellular telephone is forbidden or dangerous.
- Any other area where you would normally be advised to turn off your vehicle engine.

There may be a hazard associated with the operation of your GSM Modem close to inadequately protected personal medical devices such as hearing aids and pacemakers. Consult the manufacturers of the medical device to determine if it is adequately protected.

Operation of your GSM Modem close to other electronic equipment may also cause interference if the equipment is inadequately protected. Observe any warning signs and manufacturers' recommendations.

The modem is designed for and intended to be used in "*fixed*" and "*mobile*" applications:

- "*Fixed*" means that the device is physically secured at one location and is not able to be easily moved to another location.
- "*Mobile*" means that the device is designed to be used in other than fixed locations and generally in such a way that a separation distance of at least 20 cm (8 inches) is normally maintained between the transmitter's antenna and the body of the user or nearby persons.

The Modem is not designed for and intended to be used in portable applications (within 20 cm or 8 inches of the body of the user) and such uses are strictly prohibited.

9.2 Vehicle Safety

Do not use your GSM Modem while driving, unless equipped with a correctly installed vehicle kit allowing 'Hands-Free' Operation.

Respect national regulations on the use of cellular telephones in vehicles. Road safety always comes first.

If incorrectly installed in a vehicle, the operation of GSM Modem telephone could interfere with the correct functioning of vehicle electronics. To avoid such problems, make sure that the installation has been performed by a qualified personnel. Verification of the protection of vehicle electronics should form part of the installation.

The use of an alert device to operate a vehicle's lights or horn on public roads is not permitted.

9.3 Care And Maintenance

Your GSM Modem is the product of advanced engineering, design and craftsmanship and should be treated with care. The suggestion below will help you to enjoy this product for many years.

Do not expose the GSM Modem to any extreme environment where the temperature or humidity is high.

Do not use or store the GSM modem in dusty or dirty areas. Its moving parts (SIM holder for example) can be damaged.

Do not attempt to disassemble the GSM Modem. There are no user serviceable parts inside.

Do not expose the GSM Modem to water, rain or spilt beverages. It is not waterproof.

Do not abuse your GSM Modem by dropping, knocking, or violently shaking it. Rough handling can damage it.

Do not place the GSM Modem alongside computer discs, credit or travel cards or other magnetic media. The information contained on discs or cards may be affected by the modem.

The use of third party equipment or accessories, not made or authorized by Wavecom may invalidate the warranty of the GSM Modem.

Do contact an authorized Service Center in the unlikely event of a fault in the GSM Modem.

9.4 Your Responsibility

This GSM Modem is under your responsibility. Please treat it with care respecting all local regulations. It is not a toy. Therefore, keep it in a safe place at all times and out of the reach of children.

Try to remember your Unlock and PIN codes. Become familiar with and use the security features to block unauthorized use and theft.

10 Recommended accessories

Accessories recommended by WAVECOM for the FASTRACK M1306B modem are given in the table below.

Table 20: List of recommended accessories

Designation	Part number	Supplier
Dual-band antenna	1140.26	ALLGON
SMA/FME Antenna adaptor		PROCOM
Power adaptor (Europe)	To Be Completed*	To Be Completed*
Audio accessories	To Be Completed*	To Be Completed*

* Information not available for this preliminary version.

Preliminary